

# INSTRUCTIONS MANUAL

## PROFESSIONAL LADDERS

### Guarantee and insurance certificate:

The undersigned company Frigerio Carpenterie S.p.A. guarantees for the ladder specified below and for a period of 10 years for articles in aluminium and a period of 5 years for articles in fibreglass, starting from the purchase date, replacement or repair free of charge for parts resulting as defective due to materials or machining; it also insures against any damages caused to property or people caused by the same parts if ascertained as having left the production plant in defective condition.

The following are not included in this guarantee:

- defects or breakages and all consequences caused by misuse and/or lack of compliance, even if only in part, with that indicated in the instructions and/or that prescribed by the specific current standards.
- Damage caused by wear or atmospheric agents
- Interventions for presumed defects or convenience inspections

This guarantee is not valid in the case of mishandling or repairs carried out by persons not authorised by Frigerio Carpenterie S.p.A. or if carried out using non-original spare parts.

Ladder model: \_\_\_\_\_ Date of purchase: \_\_\_\_\_

Serial Number, if any -  
Manufacture month/year:

Stamp and signature  
of Retailer:



CONTENT	
REASONS FOR ACCIDENTS - MARKING AND STICKERS	pag. 2
ADHESIVES AND PICTOGRAMS	pag. 3
GENERAL USE WARNINGS	pag. 4
MAINTENANCE and CONTROLS and TRAINING	pag. 5
• 680 - 680N - V080 - V080N - 3046N - 5048N	pag. 6
• 3051N - 3060N - V051N - V060N - 3051NV - 3060NV	pag. 7
• 1959N	pag. 8
• 3045/3045Z - 3047/3047Z - V045/V045Z - V047/V047Z	pag. 9
• 1970	pag. 10
• 3043	pag. 11
• 6026/6026T - 6040/6040T - V026 - 6046	pag. 12
• 6016 - 1969/1969S	pag. 13
• 1980/1980S	pag. 14
• 6085 - 6087	pag. 15
• 6082N - 6082C	pag. 16
• 6083 - 6083A	pag. 17
• 6088 - 6088P	pag. 18
• 6015 - 6025 - 6008	pag. 19
• 6028N - 6048N - 6028 - 6048	pag. 20
• 6078N - 6078	pag. 21
• 6080	pag. 22
• V100	pag. 23
• 693	pag. 24
• GENERAL ACCESSORIES	pag. 25
• TALIAN LEGISLATION Leg. Decree no.81 and DECLARATION OF CONFORMITY	pag. 27
• STING AND CONFORMITY	pag. 28

This manual is based on the provisions of Leg. Decree no.81 and pursuant to standard EN131-3 for products certified according to requirements: EN131-1 (terms, types and functional dimensions of leaning ladders and/or double ladders), EN131-2 (requirements, testing and marking for leaning ladders and/or double ladders), EN131-4 (multi-position transformable ladders with hinges), EN131-7 or NFP093-352/53 (anti-overturning platform ladder), EN50528 (low voltage isolation for fibreglass ladders).



## REASONS FOR ACCIDENTS

The following is a non-exhaustive list of the dangers and examples of frequent causes of accidents which can occur when using the ladders and on which the information contained in this manual is based.

### Loss of stability:

- Incorrect position of the ladder (for example: incorrect angle of a leaning ladder or incomplete opening of a double ladder).
- Sliding outwards from the base (for example: the bottom of the ladder moves away from the wall).
- Sliding sideways, falling sideways and overturning (for example: protruding or due to the fragility of the upper contact surface).
- Condition of the ladder (for example: non-slip feet missing).
- Climbing down the ladder or climbing up to a height when the ladder is not secure.
- Ground conditions (for example: if the ground is soft or unstable, on slopes, slippery surfaces or soiled solid surfaces).
- Poor climatic conditions (for example: wind).
- Collision with the ladder (for example: by a vehicle or a door).
- Incorrect choice of ladder (for example: ladder too short or not suitable for the specific use).

### Movement:

- Transfer of the ladder to the work position.
- Assembly and dismantling of the ladder.
- Transport of objects on the ladder.

## MARKING and STICKERS

Read all the data carefully on the ladder stickers, paying particular attention to the maximum working load and the use height and the specific instructions of the product purchased by you on the following pages.

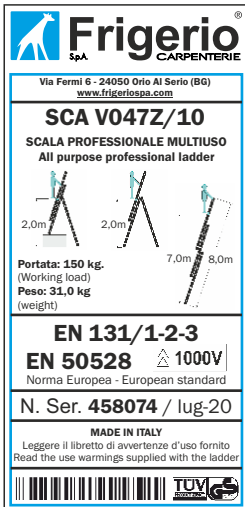

**Frigerio**  
S.p.A. CARPENTERIE

Via Fermi 6 - 24050 Orio Al Serio (BG)  
www.frigeriospa.com

**SCA V047Z/10**  
SCALA PROFESSIONALE MULTIUSO  
All purpose professional ladder



Portata: 150 kg.  
(Working load)  
Peso: 31,0 kg  
(weight)

EN 131/1-2-3  
EN 50528  $\Delta$  1000V  
Norma Europea - European standard

N. Ser. 458074 / lug-20

MADE IN ITALY  
Leggere il libretto di avvertenze d'uso fornito  
Read the use warnings supplied with the ladder



**Frigerio**  
S.p.A. CARPENTERIE

Via Fermi 6 - 24050 Orio Al Serio (BG)  
www.frigeriospa.com

**SCA 6026/08**  
SCALA PROFESSIONALE CAVALLETTO  
Professional trestle ladder



Portata: 150 kg.  
(Working load)  
Peso: 10,0 kg  
(weight)

EN 131/1-2-3

Norma Europea - European standard

N. Ser. 435560 / mag-20

MADE IN ITALY  
Leggere il libretto di avvertenze d'uso fornito  
Read the use warnings supplied with the ladder



**Frigerio**  
S.p.A. CARPENTERIE

Via Fermi 6 - 24050 Orio Al Serio (BG)  
www.frigeriospa.com

1000V

Non usare, non maneggiare, né montare o smontare il prodotto se il contatto con il conduttore di energia elettrica è possibile. Non usare il prodotto se il contatto con il conduttore di energia elettrica è possibile. Do not use, do not handle, do not assemble or disassemble the product if there is a risk of contact with the live parts. Do not use the product if there is a risk of contact with the live parts. Do not use the product if there is a risk of contact with the live parts.



### Slipping, tripping, falling operator:

- Unsuitable footwear.
- Soiled rungs or steps.
- Unsafe actions by the user (for example: climbing up the ladder two rungs at a time or sliding down the upright profiles).

### Structural failure of the ladder:

- Unsuitable footwear.
- Ladder conditions (for example: upright profiles, hinges or steps damaged, worn).
- Ladder overloaded.

### Electrical hazards:

- Inevitable operations on live parts (for example: searching for faults).
- Positioning of the ladder too near live electrical equipment (for example: overhead electricity lines).
- Damage to electrical equipment (for example: protective coverings and insulation) caused by the ladders.
- Incorrect choice of type of ladder for electrical works (for example: use of non-insulating ladders or not equipped with electrical isolation certification or equipped with insulating capacity differing from the specific use on-site).

### Identification of the ladder:

If communicating with the manufacturer or the dealer, state the product code or, if necessary, the serial number and year of manufacture. .



**Frigerio**  
S.p.A. CARPENTERIE

Via Fermi 6 - 24050 Orio Al Serio (BG)  
www.frigeriospa.com

**SCA A CAVALLETTO**  
STANDING LADDER  
ECHELLE DOUBLE



MAX. 1

ULTIMO GRADINO UTILIZZABILE  
Vedi manuale istruzioni d'uso  
LAST USEFUL STEPS  
See instruction manual  
DERNIERE ÉCHELLE UTILISABLE  
voir le manuel d'instructions

Frigerio  
www.frigeriospa.com



**Frigerio**  
S.p.A. CARPENTERIE

Via Fermi 6 - 24050 Orio Al Serio (BG)  
www.frigeriospa.com

**SCA D'APPoggio**  
LEANING LADDER  
ECHELLE EN APPUI



MAX. 1

ULTIMO GRADINO UTILIZZABILE  
Vedi manuale istruzioni d'uso  
LAST USEFUL STEPS  
See instruction manual  
DERNIERE ÉCHELLE UTILISABLE  
voir le manuel d'instructions

Frigerio  
www.frigeriospa.com

## ADHESIVES AND PICTOGRAMS

The basic information is outlined in a clearly visible format on the adhesive of each ladder produced.

The square pictograms with a green or blue border illustrate a positive action to follow while the round pictograms with a red border illustrate a forbidden action.

*N.B. If the adhesive is damaged or very worn, you can inform our office to request a new one*

Secure the base and top of the ladder



Minimum extension of the ladder over the arrival point

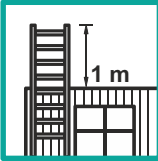

Read the instructions



Maximum permitted load

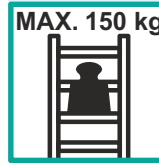

Check intactness of the ladder support feet



Ensure the ladder is fully open

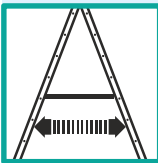

Ensure all the safety devices against accidental opening and closure are activated and locked

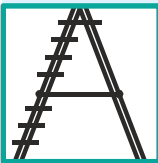

Correct support angle

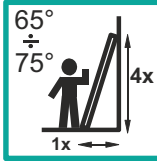

Visual inspection before use

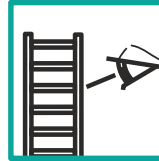

Maximum number of users on ladder



Use the ladder with the correct orientation



Do not stand on top step



Position and use the ladder on flat ground



Do not use the ladder as a bridge



Do not hang over it sideways and keep the centre of gravity at the centre of the ladder



Pay attention to electrical hazards when using and transporting the ladder



Ensure there is no dirt, water or oil on the ground



Position and use the ladder on solid ground



Ensure the top of the ladder is correctly positioned



Do not climb down the sides of the ladder to access raised surfaces



Turn towards the ladder both when climbing up and down it



Access to the climbing ramp is permitted to one person at a time



## GENERAL USE WARNINGS

### Before use:

- Ensure you are physically fit enough to use the ladder. Certain medical conditions, use of medicine, or abuse of alcohol or drugs could make use of the ladder unsafe
- If the ladder is transported on a roof rack or a truck, ensure it is correctly positioned to avoid damage;
- Inspect the ladder after delivery and before first use to check the conditions and operation of all its parts;
- Visually inspect the ladder is not damaged and that it can be used safely at the start of each working day;
- For professional users, regular periodic inspection is required, at most every 100 hours of use;
- Ensure the ladder is suitable for the specific use;
- Do not use damaged ladders;
- Remove every trace of dirt, such as fresh paint, mud, oil or snow from the ladder;
- Before using a ladder in the workplace, a risk assessment should be carried out in compliance with legislation in the country of use.

### Positioning and assembly of the ladder:

- The ladder must be assembled in the correct position, i.e. with the correct angle for a leaning ladder (between 65° and 75° with a ratio of 1:4) and completely open for a double ladder; If the ladder is equipped with flat or deep steps over 5 cm, the ladder should be positioned to keep the steps in the horizontal position
- The anti-closure and anti-opening safety devices if planned, must be completely blocked before use;
- The ladder must be on a flat, horizontal and non-moving base;
- A leaning ladder must rest against a non-fragile surface and be secured before use, for example tying it or using a suitable stabilisation device
- The position of the ladder must never be changed from above;
- When the ladder is positioned, remember the risk of collision with it, for example, with pedestrians, vehicles or doors;
- Identify all the electrical risks in the work area, such as lines or other exposed electrical equipment;
- The ladder must rest on its feet and not on the rungs or steps;
- The ladder must not be positioned on slippery surfaces (such as ice, polished surfaces or very soiled solid surfaces), unless suitable measures are taken to avoid the ladder slipping or ensure sufficient cleaning of the dirty surface.

### Using the ladder:

- Do not exceed the total maximum load for the type of ladder;
- Do not hang off the ladder; the user's belt buckle should be inside the upright on both feet on the same step/rung during the entire operation;
- Do not leave the ladder to access another location at a height without additional safety, such as a tying system or suitable stabilisation device; do not use double ladders to access another level;
- Do not stay on the three highest steps/rungs of a leaning ladder;
- Do not stay on the two highest steps/rungs of the double ladder without a platform and body-guard;
- Do not stay on the four highest steps/rungs of a double ladder with cantilevered section or however not beyond the top of the scissors/stand/intersection of the round sections. Use the cantilevered section as a handhold only;
- The ladders should only be used for light and short works;
- Use non-conductive ladders to carry out works on live electrical parts;
- Do not use the ladder outdoors, in bad weather conditions such as strong wind;
- Take precautions to avoid children playing on the ladder;
- Secure the doors (except the fire-escape exits) and the windows, where possible, in the work area;
- Face the ladder when climbing up and down;
- Keep a safe grip on the ladder when climbing up and down;
- Do not use the ladder as a bridge;
- Wear suitable footwear to climb on the ladder;
- Do not spend long periods of time on the ladder without regular breaks (tiredness can contribute to risk);
- Leaning ladders used to access a higher level must extend by at least 1 metre over the arrival point, as well as be anchored to a fixed part as outlined in Legislative Decree no.81 from 2008;
- The equipment transported on the ladder must be light and manageable;
- Avoid excess side loads, for example lifting packs that are too heavy;
- Avoid operations requiring application of side thrust such as solid material perforation (bricks-cement) on leaning and double ladders, if not compliant with standard EN131-7 and however within the terms planned by the standard (not over 30 kg. horizontally);
- Maintain a support while using the ladder, or implement the safety precautions if this is not possible;
- The length of the ladder must not be increased by tying together multiple ladders or fastening extensions on the uprights;
- Do not use a double ladder as a support (so-called scissors or stand).

### Ladder demolition:

- Ladders must not be disposed of in the environment, but delivered to the specific, authorised collection centres.

### Repair and cleaning:

- Repairs must only be carried out by competent staff, compiling the following data sheet. Contact the Frigerio dealers or directly contact Frigerio Carpenterie S.p.A. on 035-4242311.
- Ladders must be cleaned with a damp cloth using water or alcohol.

Date	Intervention description	Technical signature

## MAINTENANCE and CONTROLS

Our aluminium or fibreglass ladders do not need any particular maintenance or periodic servicing, but you are recommended to take note of the general warnings in this manual and the specific use instruction for the model used, described on the following pages and keep the ladders away from atmospheric agents, oxidants and corrosive substances.

You are also advised to safeguard ladders to avoid improper use. The manufacturer cannot be held in any way liable for damage to people or property which can derive from improper use of the ladders and total or partial non-compliance with the standards outlined in this manual and those in force, or non-compliance with periodic controls or maintenance against possible damage caused by use or atmospheric agents.

For this reason, AT LEAST EVERY 100 HOURS AND BEFORE EACH USE, CAREFULLY CHECK THE ELEMENTS ARE INTACT and, if necessary, signal any deficiencies found to your manager (Art. 18-9-20 Leg. Decree no.81: worker and supervisor obligations) and comply with the provisions of safety legislation.

Date of inspection day/month/year	Ladder model article code	Components checked yes/no	Components cleaned yes/no	Rungs and uprights intact yes/no	Feet intact yes/no	Anti-extension and anti-opening devices intact yes/no	Welding intact yes/no	No rust yes/no	Stickers intact yes/no

## USER TRAINING and INFORMATION

In compliance with the provisions of Art. 36, 37 and 73 of Legislative Decree no.81 on 9 April 2008, I declare to have consulted the manual outlining the instructions for use and maintenance of the ladder and I am therefore informed and trained in the health and safety risks, on the safety measures and the hazards relating to its use.

Date	Operator's name and surname	Operator's signature	Company stamp and signature

**ATTENTION !** - Before using the ladder, read and understand the general provisions outlined from page 2 to 5



## LADDER WITH 1 ELEMENT runged

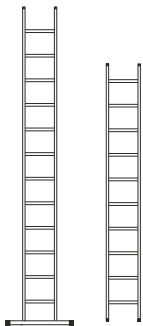

### 1) Assemble the stabiliser base :

(Only for models with 11 steps upwards)

- Remove the impact-proof safety plugs on the end of the ground support and completely insert the pins inside the upright profiles,
- Insert the specific through-screw on the upright fixing hole and tighten the bolt with manual strength only;

(For fibreglass models only)

Instead of the pins, use safety boxes in aluminium where insertion is necessary of the fibreglass upright profiles.

*N.B.* When used on the last available step at a height over 2 m the ladder must be anchored to avoid danger of slipping

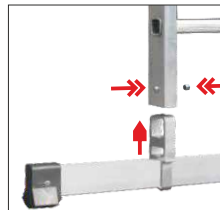

*N.B.* Articles **SCA 680N** and **SCA V080N up to measurement 10** do not have a stabiliser base because it is not required by UNI EN 131.

### ARTICLES MADE

Art. **SCA 680N** / 06-07-08-09-10-11-12-13-14-15-16-17-18-19-20-21

Art. **SCA V080N** / 06-07-08-09-10-11-12-13-14-15-16-17-18-19-20-21

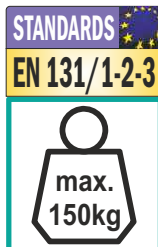

**Last available step** = fourth last step

## LADDER WITH 2 OR 3 ELEMENTS WITH MANUAL EXTENSION runged

**ATTENTION DANGER OF SHEARING:**

The user must ensure that while the extension extends or retracts the upper elements there is nobody resting their hands on the rungs.

*N.B.* When used on the last available step at a height over 2 m the ladder must be anchored to avoid danger of slipping.

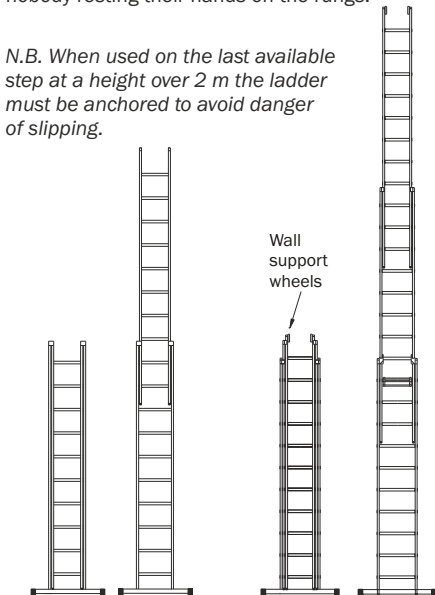

**Last available step** = fourth last step

### 1) Assemble the stabiliser base:

- Remove the impact-proof safety plugs on the end of the ground support and completely insert the pins inside the upright profiles,
- Insert the specific through-screw on the upright fixing hole and tighten the bolt with manual strength only;

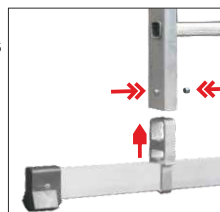

### 2) Ladder extension :

(For models with 2 elements only)

- With the ladder laying on the ground, manually extend the 2nd element up to the desired length, locking the anti-extension hooks on the first available step,
- Lean the ladder on the wall, keeping the narrowest element turned towards the user;

(For models with 3 elements only)

- Keeping the narrowest element turned towards the user, rest the sliding wheels on the wall,
- First elongate the 3rd element up to the desired length by blocking the anti-extension hooks on the first available step, then elongate the 2nd element to the desired length, blocking the anti-extension hooks on the first available step.

*N.B.* The ladder versions 3046 and 5048 not equipped with a stabiliser base or base widener and used over 8 m extension require use of a compulsory cross section (see page 22).

### ARTICLES MADE

Art. **SCA 3046N** / 06-07-08-10-12-14

Art. **SCA 5048N** / 08-10-12-14

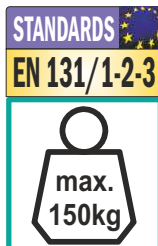

**ATTENTION !** - Before using the ladder, read and understand the general provisions outlined from page 2 to 5



## EXTENSION LADDER WITH 2 OR 3 ELEMENTS WITH ROPE runged

ATTENTION: Before using the ladder, always check the presence of the red safety elastic and that the pulleys and the anti-extension rocker arm mechanism are obstacle-free and working without force.



ATTENTION: Before climbing on the ladder, always check the anti-extension hook on the desired rung is correctly blocked.

ATTENTION: The rocker arm locking device guarantees automatic locking if the operator accidentally releases the rope during extension or retraction of the ladder.

**ATTENTION DANGER OF SHEARING:**  
The user must ensure that while extending or retracting the upper elements, there is nobody resting their hands on the rungs of the base element.

*N.B. When used on the last available step at a height over 2 m the ladder must be anchored to avoid danger of slipping.*

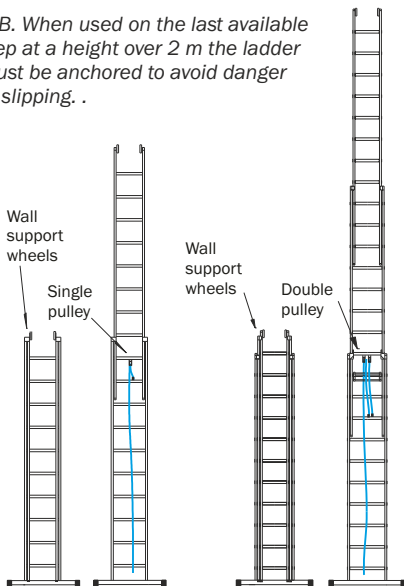

**Last available step** = fourth last step

### 1) Assemble the stabiliser base :

- Remove the impact-proof safety plugs on the end of the ground support and completely insert the pins inside the upright profiles,
  - Insert the specific through-screw on the upright fixing hole and tighten the bolt with manual strength only;
- (For fibreglass models only)

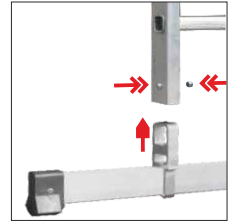

Instead of the pins, use safety boxes in aluminium where insertion is necessary of the fibreglass upright profiles.

### 2) Ladder extension:

- Keeping the narrowest element turned towards the user, rest the sliding wheels on the wall,
- Manually elongate the 3rd element up to the desired length by blocking the anti-extension hooks on the first available step,
- On the internal side, pull the rope downwards to extend the extension of both the upper round sections up to when the stoppage rocker arm exceeds the desired locking step;

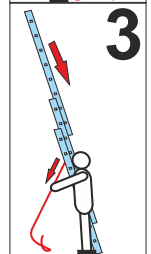
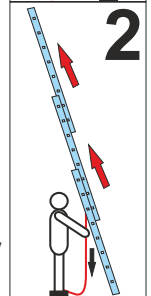
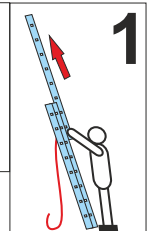

### 4) Ladder retraction

- Pull the rope downwards by approx. 10 cm,
- Move your hand moving the rope on the inside of the ladder towards the wall up to rotation of the rocker arm, thereby disabling automatic locking,
- When maintaining the position of your hand, slowly release the rope to then retract the extension (Locking can take place at any time bringing your hand moving the rope towards the ladder to rotate the rocker arm again in the automatic locking position).

*N.B. Ladder versions 3051, 3060, V051, V060, 3051V and 3060V not equipped with a stabiliser base or base widener and used over 8 m extension require use of a compulsory cross section (see page 22).*

### ARTICLES MADE

Art. **SCA 3051N** / 12-14-16-18

Art. **SCA 3060N** / 10-12-14-16

Art. **SCA V051N** / 12-14-16-18

Art. **SCA V060N** / 10-12-14-16

Art. **SCA 3051N** / 12V-14V-16V-18V

Art. **SCA 3060N** / 10V-12V-14V-16V

**STANDARDS**  
**EN 131/1-2-3**



**ATTENTION !** - Before using the ladder, read and understand the general provisions outlined from page 2 to 5



## EXTENSION LADDER WITH 2 OR 3 ELEMENTS WITH WINCH runged

**ATTENTION:** Before using the ladder, check the winch, the pulleys and the spring mechanism of the anti-extension pop-up are working and obstacle-free.



**ATTENTION:** Before climbing on the ladder, always check the anti-extension pop-up on the desired rung is correctly locked.

**ATTENTION:** The winch is equipped with a safety clutch that avoids accidental extension of the elements.

**ATTENTION DANGER OF SHEARING:** The user must ensure that while extending or retracting the upper elements there is nobody resting their hands on the rungs.

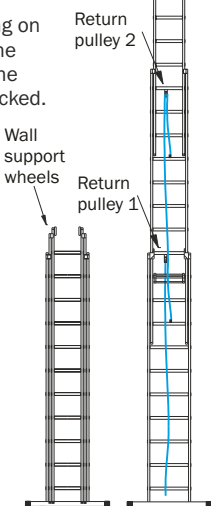

1) **Assemble the stabiliser base:**  
- Remove the impact-proof safety plugs on the end of the ground support and completely insert the pins inside the upright profiles,  
- Insert the specific through-screw on the upright fixing hole and tighten the bolt with manual strength only,  
- Loosen both the black knobs on the base and extend their ends to the maximum length, then tighten both knobs again manually;

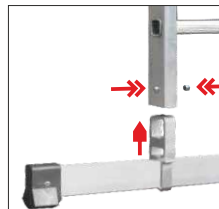

2) **Ladder extension:**  
- Keeping the narrowest element turned towards the user, rest the sliding wheels on the wall,  
- Use the handle of the winch to extend the ladder until the pop-up exceeds the desired locking step;

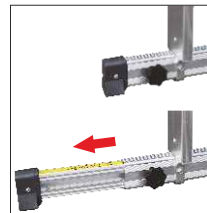

3) **Ladder retraction:**  
- Half turn the handle in the up direction to extend the ladder a further 10 cm to disable the locking pop-ups, then rotate the winch in the opposite direction to retract the ladder extension (Lock at any time by extending the ladder again to the desired step).



*N.B. When used on the last available step at a height over 2 m the ladder must be anchored to avoid danger of slipping.*

*N.B. The ladder versions 1959 not equipped with a stabiliser base or base widener and used over 8 m extension require use of a compulsory cross section (see page 22)..*

### ARTICLES MADE

Art. **SCA 1959N** / 14-16-18

**STANDARDS**  
**EN 131/1-2-3**



**ATTENTION: Article SCA 1959N/20 complies with Leg. Decree no.81 only and requires a compulsory cross section when used extended over 13.73 m (see page 22)**

### ARTICLES MADE

Art. **SCA 1959N** / 20

**STANDARDS**  
**D.Lgs. 81**



**Last available step** = fourth last step

**ATTENTION !** - Before using the ladder, read and understand the general provisions outlined from page 2 to 5





## ALL PURPOSE LADDER WITH 2 OR 3 ELEMENTS WITH MANUAL EXTENSION runged

ARTICLES MADE
Art. <b>SCA 3045</b> / 06-07-08-16
Art. <b>SCA 3045Z</b> / 10-12-14
Art. <b>SCA 3047</b> / 06-07-12-14
Art. <b>SCA 3047Z</b> / 08-09-10-11
Art. <b>SCA V045</b> / 08-16
Art. <b>SCA V045Z</b> / 10-12-14
Art. <b>SCA V047</b> / 07-12-14
Art. <b>SCA V047Z</b> / 08-09-10-11

**Last available step in extended use =** fourth last step  
**Last available step in stand use =** for the version with 2 elements: third last step  
 for the version with 3 elements: step placed on the intersection between the 1st and 2nd element

**ATTENTION DANGER OF SHEARING:**  
 The user must ensure that while the scissors/trestle ladder opens and when closing again, or when extending and retracting the extension of the upper elements, nobody has their hands placed on the rungs.

**STANDARDS**   
**EN 131/1-2-3**  

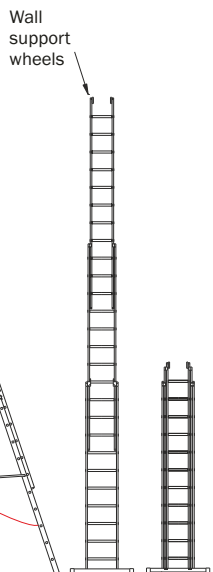

- 1) Assemble the stabiliser base:
  - Remove the impact-proof safety plugs on the end of the ground support and completely insert the pins inside the upright profiles,
  - Insert the specific through-screw on the upright fixing hole and tighten the bolt with manual strength only;

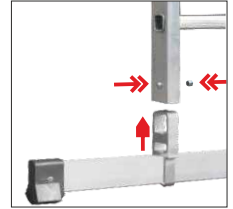

(For fibreglass models only)

Instead of the pins, use safety boxes in aluminium where insertion is necessary of the fibreglass upright profiles;

- 2) Ladder extension and ladder opening  
 (For models with 2 elements in extended use only)

- With the ladder laying on the ground, manually extend the 2nd element up to the desired length, blocking the anti-extension hooks on the first available step,
- Lean the ladder on the wall, keeping the narrowest element turned towards the user;



(For models with 3 elements in extended use only)

- Keeping the narrowest element turned towards the user, rest the sliding wheels on the wall,
- Elongate the 3rd element up to the desired length, blocking the anti-extension hooks on the first available step and then elongating the 2nd element up to the desired length, blocking the anti-extension hooks on the first available step;

(For models with 2 or 3 elements in stand use)

- Position and maintain the ladder on its feet near the height difference,



- Release the anti-extension hook on the 1st element, then lift the 2nd element (to compensate for any height differences for versions «Z») and distance it completely, ensuring the upper hinge is in place with the pin (or in place with the step for versions «Z»),
- Turn the anti-closure spacer bars towards the 2nd element and couple the tab outside the first available rung,
- If available, extend the 3rd element to allow you to rest your chest at least 1 m over the last available rung placed on the cross section between the 1st and 2nd element.



*N.B. When used on the last available step at a height over 2 m the ladder must be anchored to avoid danger of slipping or overturning.*

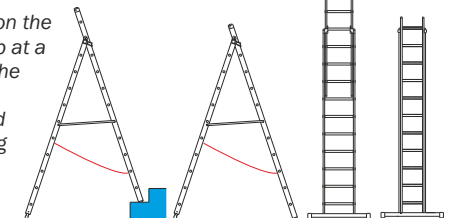

**ATTENTION !** - Before using the ladder, read and understand the general provisions outlined from page 2 to 3



## TELESCOPIC LADDER WITH MANUAL EXTENSION runged

### 1) Open the ladder in the use position:

This ladder is equipped with a manual locking hinge and on each position change, you must:

- Release both the hinges by pulling the knob outwards to rest on the pins on the external surface in the rest position,
- Adjust opening of the ladder towards the desired position (stand use or extended use),
- Re-insert the knob in the locking holes and check complete insertion of the three pins in the position holes;

*N.B. The «free» stand position allows you to close, move and re-open the ladder quickly without intervention on the hinge, however before climbing on the ladder, ensure all the hinges are in the locked position.*

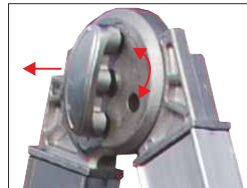

**HINGE MAINTENANCE:**  
The hinges must be clean of any dirt and regularly lubricated.

### 2) Extension and locking:

Ladder extension is adjusted by extending the external frames and locking is carried out on each step:

- Release (FREE) pulling the two telescopic hooks outwards and removing the internal section,
- Lock (LOCK) the extension by re-inserting the telescopic hooks, coupling them with the compartment of the internal section.

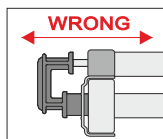
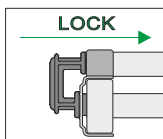
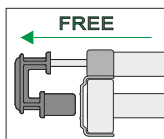

*N.B. When the last available step is used at a height over 2m the ladder must be anchored to avoid danger of slipping or overturning.*

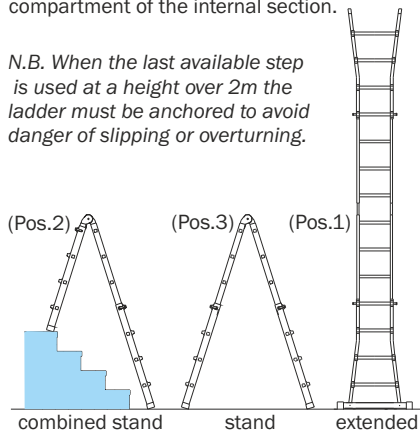

**ATTENTION:** When in use extended the ladder requires the use of the base accessory art. SCC Ba1970 mandatory for compliance with European standard EN131 part 2, part 3 and part 4 in effect.

### ARTICLES MADE

Art. **SCA 1970** / 12-14-16-18  
18R-20R-22R-24E

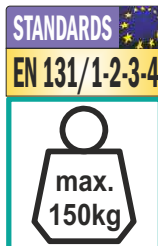

### Last available step in extended use

= fourth last step

### Last available step in stand use

= third last step

**ATTENTION:** Art. SCA 1970/24R EN131 compliant only when in use as (Pos.2 e Pos.3)

### ARTICLES MADE

Art. **SCA 1970** / 24R



### ACCESSORY Art. SCC LIV1970 - Leveller for side height differences

Applicable as you wish on each support foot of the external frames of the ladder, they are designed to compensate for slopes up to 19° to the sides of the ladder or height differences up to 18 cm.

- Loosen the fixing screws of the leveller and adjust extension of the leveller to its minimum,
- Rest the leveller on the external surface of the upright profile of the external frames of the ladder on the support feet you intend to level to keep the fixing hinges stopped under the steps.

*(N.B. The fixing position is only correct if the leveller can disable when completely retracted)*

- Lock the leveller in a safe way on the ladder, efficiently tightening the fixing screws of both the «C» hinges,
- Position the ladder and adjust the desired height of the leveller using the locking pin on the specific holes.

*N.B. To guarantee maximum adaptation capacity, Simply equip the ladder with 2 leveller parts.*

*N.B. During use of this device, the ladder references Italian standard Leg. Decree no.81 only with a maximum working load of 100 kg.*

**ATTENTION !** - Before using the ladder, read and understand the general provisions outlined from page 2 to 5



**ACCESSORY Art. SCC PIAN1970 Railing extension with rest surface**

Applicable only for a trestle ladder, work height extension of 50 cm allowing you to take full advantage of the height of the ladder, climbing on the last two steps (otherwise not accessible).

- Open the ladder in the stand position,
- Lock both the hinges in the stand position,
- Open the surface pulling the spring stop pin,
- Rest the platform on the first two steps and rotate the flat profile in aluminium beneath to fitting with the support steps,

*N.B. Before use, always check the complete and effective insertion of the spring stop pin.*

*N.B. This accessory guarantees use of the ladder in compliance with the European Standard EN131.*

**ALL PURPOSE ARTICULATED LADDER runged**

**1) Assemble the stabiliser base:**

- Fully insert the pins inside the upright profiles,
- Insert the through-screw on the fixing hole locking the upright and tighten the bolt;

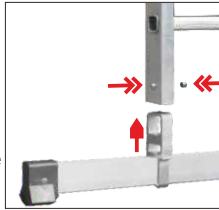

**2) Ladder extension and opening**

*(Ladder in extended use)*

- Turn the elements on the ladder unlocking each hinge to open all the hinges 180°,
- Lean the ladder on the wall;

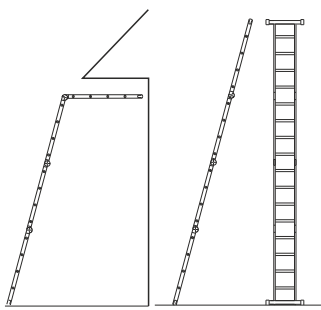

Rest with spacer      Leaning on wall

**Last available step in extended use** = fourth last step  
**Last available step in stand use** = third last step

*(Ladder in stand use)*

- Rotate the elements of the ladder, releasing each hinge to open the external hinges 180° and the central ones 30°,
- Position the ladder on its feet with both the bases resting on the ground;

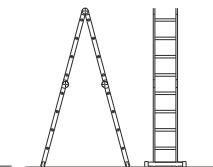

**STANDARDS**  
**EN 131/1-2-3**  
**max. 150kg**

**ARTICLES MADE**  
 Art. **SCA 3043** / 3-4

**Joints with automatic locking**

To release the hinges, pull the lever up to positioning the block on position «O», then rotate up to locking on the next position. Repeat the procedure until the desired position .



**C - CLOSED**  
**O - OPEN**



**THE HINGE LOCKS AUTOMATICALLY**

**Hinges maintenance**

The hinges must be clean of dirt and regularly lubricated.

*N.B. Before climbing on the ladder, ensure all the hinges are locked, with the block in the locking position «C».*

*(Ladder in bridge use)*

- Rotate the elements of the ladder, releasing each hinge to open the external hinges 30° and the central ones 180° ,
- Position the ladder on its feet with both the bases resting on the ground.

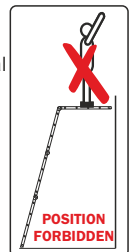

**POSITION FORBIDDEN**

**PLATFORM USE**

Art. SCA 3043/03 only allows use of the ladder as a work platform with maximum capacity of 100 kg exclusively using the surface Art. SCC 3043/3 available on request.

The platform must couple to the external rungs of the ladder bench:

Firstly insert the side of the fixed «Z» hook and then block side sliding by rotating the rotary «Z» hook.

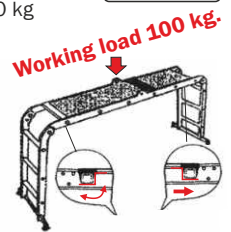

*N.B. When used on the last available step at a height over 2m the ladder must be anchored to avoid danger of slipping or overturning .*

**ARTICLES MADE**  
 Art. **SCA 3043** / 5

**STANDARDS**  
**D.Lgs. 81**  
**max. 150kg**

**ATTENTION !** - Before using the ladder, read and understand the general provisions outlined from page 2 to 5



## STANDING LADDER WITH PLATFORM stepped

**ATTENTION:** Before use, check the platform and the locking tie rod under the platform are intact, as well as the anti-opening safety strap.

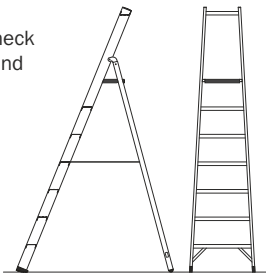

### 1) Open the ladder:

- Position the ladder on its feet and distance the ramp from the support stand until the platform rests on the cross bar and the strap is completely tight.

*N.B.*  
When used on a platform with a height over 2 m, the ladder must be anchored to avoid the danger of overturning.

### ARTICLES MADE

Art. **SCA 6026** / 03-04-05-06-07-08-09-10-12

Art. **SCA 6026T** / 03-04-05-06-07-08-09-10-12

Art. **SCA 6040** / 03-04-05-06-07-08-09-10-12

Art. **SCA 6040T** / 03-04-05-06-07-08-09-10-12

Art. **SCA V026** / 04-05-06-07-08-09

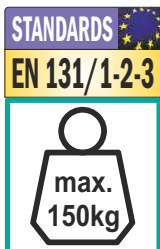

## VERSION LADDER 6026T OR 6040T with handrail and double tool tray



Install the handrail and the additional tool tray by resting the profiles on the external side of the ladder, on the locking holes already prepared, then insert the screws and tighten the bolts supplied.

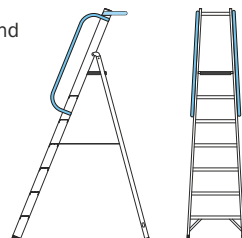

## STANDING LADDER WITH PLATFORM, HANDRAIL AND TRAY stepped

**ATTENTION:** Before use, check the intactness of the anti-opening safety mechanism under the platform and the anti-opening spacer bars, when present.

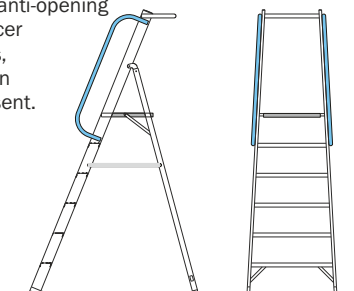

### 1) Open the ladder:

- Position the ladder on its feet and distance the ramp from the support stand until the platform rests on the cross bar and the strap is completely tight;

### 2) Install the second tool tray

- Rest the flat profiles on the external side of the ladder, on the locking holes, then insert the screws and tighten the bolts;

### 3) Install the handrails

- Rest the round profile on the external side of the ladder upright starting 1 m off the ground.  
- Insert the «C» jumper screw inside the upright profile towards the outside to meet the fixing holes of the handrails and tighten the bolts

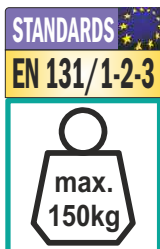

### ARTICLES MADE

Art. **SCA 6046** / 04-05-06-07-08-09-10

*N.B.* When used on a platform with a height over 2 m the ladder must be anchored to avoid danger of overturning. .

**ATTENTION !** - Before using the ladder, read and understand the general provisions outlined from page 2 to 5



## STANDING LADDER stepped

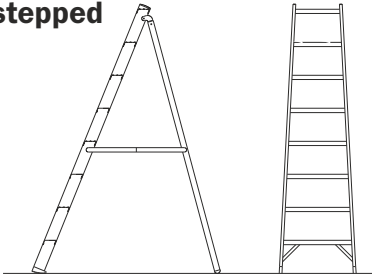

- 1) Open the ladder:  
 - Position the ladder on its feet and distance the ramp from the support stand until the spacer bars are completely spread.

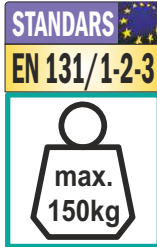
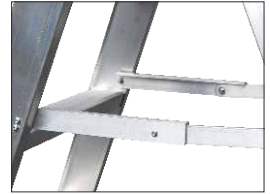

**ATTENTION :**  
 Before use check the anti-opening safety spacer bars are intact.

*N.B. When in use on the last step available at a height over 2 m, the ladder must be anchored to avoid dangerous overturning.*

### ARTICLES MADE

Art. **SCA 6016** / 06-07-08-09-10

**Last available step =** third last step

## TRIPOD CONICAL STANDING LADDER stepped

- 1) Assemble the foot of the terminal:  
 - Remove the locking pin and extend the telescopic foot up to the last available hole,  
 - Then, insert the fixing pin again;
- 2) Open the ladder:  
 - Position the ladder on its feet and distance the ramp side from the support terminal until the strap becomes completely tight.

*ATTENTION: When equipped with a terminal with pointed foot, the ladder can only be used on soft ground; To use the ladder on hard ground, use the rubber foot accessory.*

*ATTENTION: When equipped with a standard, non-adjustable terminal, the ladder can only be used on flat surfaces. To use the ladder on slopes or height differences, use the SCC STO telescopic accessory.*

*N.B. When used on the last available step at a height over 2 m the ladder must be anchored to avoid danger of overturning.*

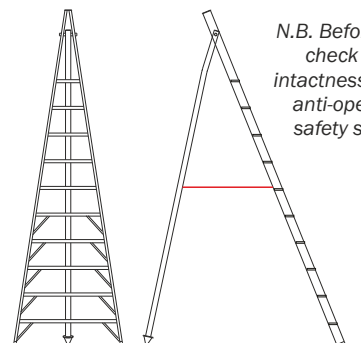

*N.B. Before use, check the intactness of the anti-opening safety strap.*

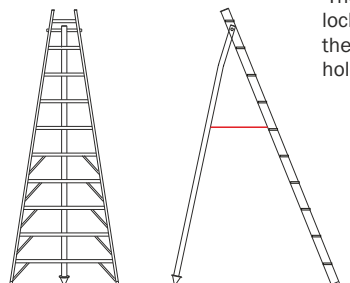

- Then, insert the locking pin again in the first available hole.



### ARTICLES MADE

Art. **SCA 1969** / 06-08-10-12-14

### ARTICLES MADE

Art. **SCA 1969S** / 06-08-10-12-14

**Last available step =** last step

**Last available step =** third last step



**ATTENTION !** - Before using the ladder, read and understand the general provisions outlined from page 2 to 5



## TELESCOPIC LADDER WITH WORK PLATFORM runged

### 1) Open the ladder in the use position:

- Position the ladder on its feet and distance the ramp from the support stand until the platform rests on the cross bar and the strap is completely tight,
- Release the objects tray platform from the rest position, turning it 180° and lock it, using the wing nut on the fixing holes (maximum working load 10 kg);



### 2) Extension and locking:

Extension of the ladder is adjusted by extending the external frames and locking is carried out on each step;

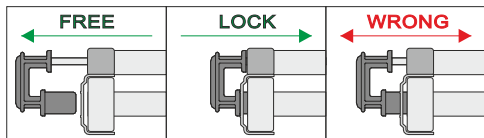

- Release (FREE) pulling the two telescopic hooks outwards and removing the internal section.
- Lock (LOCK) the extension by re-inserting the telescopic hooks, coupling them with the compartment of the rungs of the internal section.

### 3) Install the handrails

- Rest the round profile on the external side of ladder upright starting from the highest point under the tool tray
- Insert the «C» jumper screw inside the upright profile towards the outside to meet the fixing holes prepared on the handrails, insert the washers and tighten the bolts.

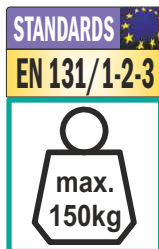
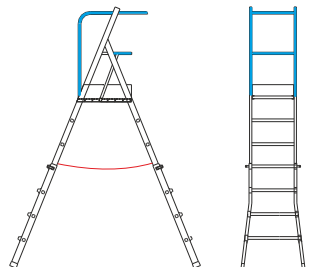

### ARTICLES MADE

Art. **SCA 1980S** / 06-10

*N.B. When used on a platform with a height over 2 m the ladder must be anchored to avoid danger of overturning.*

### VERSION LADDER 1980 WITH ANTI-OVERTURNING BRACKETS

Before climbing, stabilise the ladder using the telescopic brackets

- Open the bracket externally,
- Couple the two horizontal tie rods to the pawls on the upright of the ladder.
- Lock the two tie rods, rotating the safety discs,
- Remove the internal tube of the telescopic bracket, until it touches the ground.
- Lock the telescopic tube using the stainless steel tie.

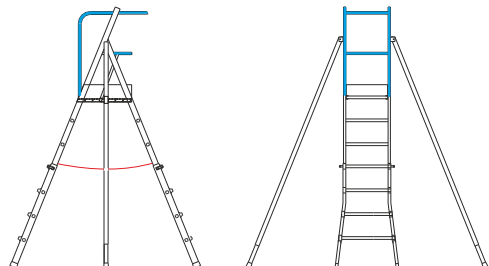
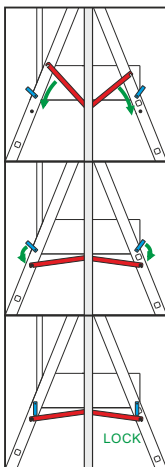
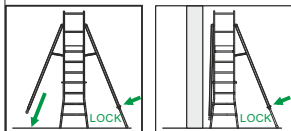

*N.B. This ladder allows active work because it was tested to compensate for side thrust up to a maximum of 30 kg horizontally. (Before use, check compatibility on the use manual of the tool or machinery used).*

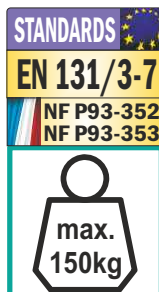

### ARTICLES MADE

Art. **SCA 1980** / 06-10

Prima di salire assicurarsi del corretto posizionamento e bloccaggio di entrambe le staffe telescopiche; quando si lavora in affiancamento a parete è possibile tenere a riposo la staffa vicino alla parete. L'operatore che lavora sulla piattaforma deve mettersi in sicurezza agganciando le fettucce poste dietro la schiena.

**ATTENTION !** - Before using the ladder, read and understand the general provisions outlined from page 2 to 5



## LADDER WITH WORK PLATFORM stepped

### 1) Open the ladder in the use position:

- Position the ladder on its feet and distance the ramp from the support stand until the platform rests on the cross bar and the strap is completely tight.
- Release the objects tray platform from the rest position, turn it 180° and lock it, using the wing nut on the fixing holes (maximum working load 10 kg.);

### 2) Install the handrails:

- Rest the round profile on the external side of ladder upright starting from the highest point under the tool tray,
- Insert the «C» jumper screw inside the upright profile towards the outside to meet the fixing holes of the handrails and tighten the bolts;



Before climbing, stabilise the ladder using the telescopic brackets:

- Open the bracket externally,
- Couple the two horizontal tie rods to the pawls on the upright of the ladder,
- Lock the two tie rods, rotating the safety discs,
- Remove the internal tube of the telescopic bracket, until it touches the ground,
- Lock the telescopic tube using the stainless steel tie.

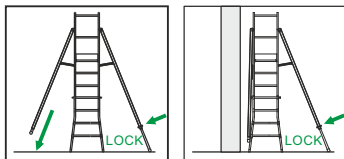
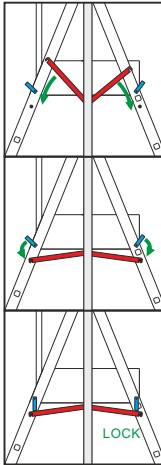

*N.B. Before climbing, ensure correct positioning and locking of both the telescopic brackets;*

*N.B. When working beside a wall, the bracket can be rested near the wall. The operator working on the platform must ensure coupling of the straps placed behind his back.*

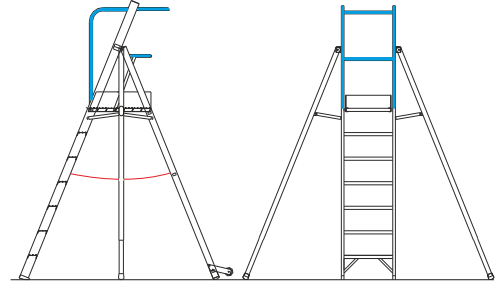

*N.B. This ladder allows active work because it was tested to compensate for side thrust up to a maximum of 30 kg horizontally. (Before use, check compatibility on the use manual of the work tool or machinery used).*

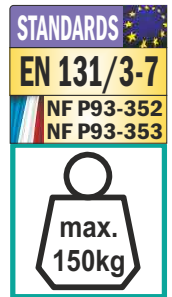
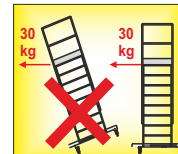

### ARTICLES MADE

Art. SCA 6085 / 04-05-06-07-08

## LADDER WITH WORK PLATFORM stepped

### 1) Install the base with wheels

- Positioning the wheels outwards of the ladder, internally insert the pins in the upright profiles of the rear stand and lock with M8x50 screws on the prepared holes;

### 2) Install the base without wheels

- Internally insert the pins inside the upright profiles of the ascent ramp and lock with the M8x20 screws on the prepared holes;

### 3) Assemble the landing

- Join the landing to the plates of the stand frame;

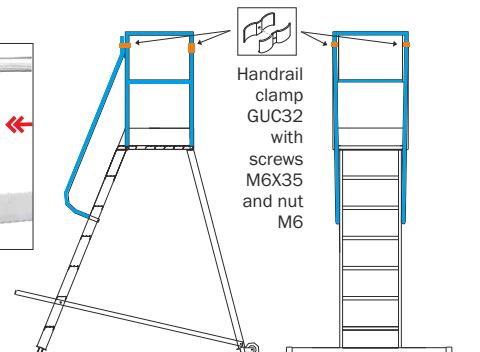
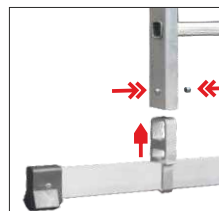

**ATTENTION !** - Before using the ladder, read and understand the general provisions outlined from page 2 to 5



to the rear end of the frame of the ascent ramp with the M8x50 screws;

4) Install the spacer tie rods outside the upright profiles using for the frame of the ascent ramp the M8x45 screws supplied, while for the stand the same screws that stop the stabiliser base with the wheels;

5) Bolt the two side rails to the profile of the platform and the footboard using the M8x45 screws and fasten the front railing frame to the two side railings using the clamp GUC32 high 10cm with screws M6x35;

7) Assemble the two handrails firstly on the railing with the clamp GUC32 high 5 cm with screws M6x35, then resting the round profile on the external side of the ladder upright and locking it using the «C» jumper screw inside the



upright profile outwards to match the fixing holes of the handrails and tighten the bolts.

*N.B. Questa scala consente il lavoro attivo perche è stata testata per compensare spinte laterali fino ad un massimo di 30 kg orizzontali. (Prima dell'utilizzo verificare la compatibilità sul manuale strumento di lavoro utilizzato).*



#### ARTICLES MADE

Art. **SCA 6087** / 03-04-05  
06-07-08

**STANDARDS**

**EN 131/3-7**

**NF P93-352**  
**NF P93-353**

**max. 150kg**

## LADDER WITH WORK PLATFORM stepped

1) Assemble the stabiliser base:

- Position the base with the wheels towards the exterior of the ladder, then insert the upright profiles of the stand inside the coupling boxes of the base and lock with the pass-through screws and bolts supplied;

2) Open the ladder in the use position:

- Position the ladder on its feet, open the hinge of the spacer bars pulling the unlocking lever and distance the ramp side from the support stand until the platform rests on the cross bar and the hinges reach the position and locking at 180° ,

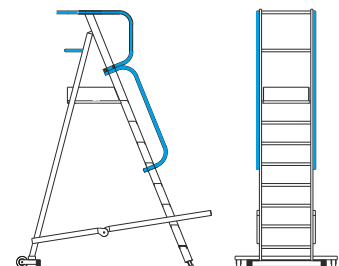

- Release the objects platform from the rest position, turning it 180° and locking it, with the wing nut on the fixing holes (maximum working load 10 kg);



4) Install the handrails

- Rest the round profile on the external side of ladder upright starting from the highest point under the tool tray,  
- Insert the «C» jumper screw inside the upright profile towards the outside to meet the fixing holes of the handrails and tighten the bolts.



#### VERSION ANTI-OVERTURNING LADDER 6082C with ballast rear base

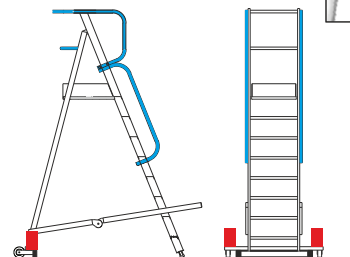

*N.B. Before climbing, check the ballast box is complete and well fastened to the rear base.*

*N.B. This ladder allows active work because it was tested to compensate for side thrust up to a maximum of 30 kg horizontally.*

*(Before use, check compatibility on the use manual of the work tool used).*



#### ARTICLES MADE

Art. **SCA 6082C** / 04-05-06-07-08-09-10

**STANDARDS**

**EN 131/3-7**

**NF P93-352**  
**NF P93-353**

**max. 150kg**

*N.B. When used on a platform with a height over 2 m the ladder must be anchored to avoid danger of overturning.*

#### ARTICLES MADE

Art. **SCA 6082N** / 04-05-06-07-08-09-10-12-14-16-17

**STANDARDS**

**EN 131/1-2-3**

**max. 150kg**

**ATTENTION !** - Before using the ladder, read and understand the general provisions outlined from page 2 to 5



## LADDER WITH WORK PLATFORM stepped

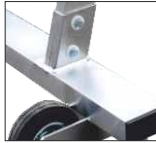

- 1) Assemble the stabiliser base:
  - Position the base with the wheels towards the exterior of the ladder, then insert the upright profiles of the stand inside the coupling box of the base and lock with the through-screws and bolts provided;
- 2) Open the ladder in the use position:
  - Position the ladder on its feet and distance the ramp side from the support stand until the platform rests on the cross bar,
  - Release the objects tray platform from the rest position, turning it 180° and lock it, using the wing nut on the fixing holes (maximum working load 10 kg);
- 3) Install the spacer tie rods
  - Couple the end of the tie rod to the stand with the through-screws provided on the holes prepared and on the ramp side screw in the locking handwheel on the proposed screw inserts;
- 4) Install the handrails
  - Rest the round profile on the external side of the ladder upright starting on the highest point under the tool tray
  - Insert the «C» jumper screw inside the upright profile towards the outside to meet the fixing holes of the handrails and tighten the bolts.

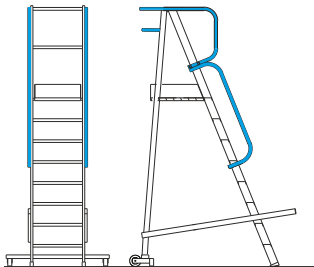

*N.B. When used on a platform with a height over 2 m the ladder must be anchored to avoid danger of overturning.*

### ARTICLES MADE

Art. **SCA 6083** / 04-05-06-07-08-09-10-12-14-16-17

**STANDARDS**  
**D.Lgs. 81**



## VERSION LADDER 6083A WITH ANTI-OVERTURNING BRACKETS

Before climbing, stabilise the ladder using the telescopic brackets:

- Open the bracket externally,
- Couple the horizontal tie rod to the pawl placed on the tie rod of the ladder,
- Lock the tie rod, rotating the safety disc,
- Remove the internal tube of the telescopic bracket, until it touches the ground,
- Lock the telescopic tube using the stainless steel tie.

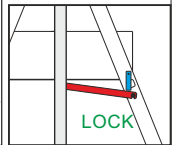
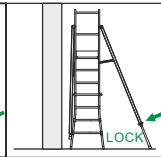
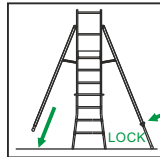
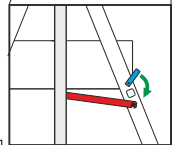
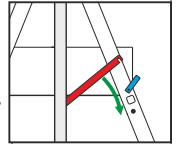

*N.B. Before climbing, ensure correct positioning and locking of both the telescopic brackets.*

*N.B. When working beside a wall, the bracket can be rested near the wall.*

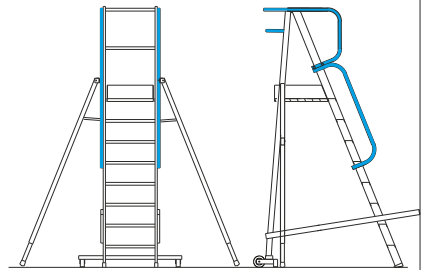

*N.B. This ladder allows active work because it was tested to compensate for side thrust up to a maximum of 30 kg horizontally.*

*(Before use, check compatibility on the use manual of the work tool used).*



**STANDARDS**  
**EN 131/3-7**  
**NF P93-352**  
**NF P93-353**

### ARTICLES MADE

Art. **SCA 6083A** / 04-05-06-07-08-09-10-12-14



**ATTENTION !** - Before using the ladder, read and understand the general provisions outlined from page 2 to 5



## DOUBLE LADDER WITH BRIDGE WORK PLATFORM stepped

### 1) Install the stabiliser bases

- Internally insert the pins of the bases inside the upright profiles of the ascent ramps and lock with the M8x20 screws on the holes prepared, positioning the wheels externally of the ladder;

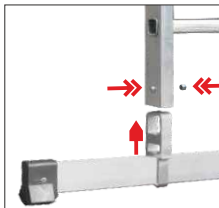

### 2) Assemble the landing

- Join the landing to the ascent ramps with the M8x50 screws on the fixing plates;

3) Install the spacer tie rods on the outside of the upright profiles using on one side the holes prepared on the ascent ramp frame and the M8x45 screws supplied, while for the other side, the same screws and the holes to stop the stabiliser base with the wheels;

4) Bolt the two side rails to the profile of the platform and the footboard using the M8x45 screws and fasten the front railing frame to the two side railings using the M8x60 screws;



5) Assemble the handrails firstly on the railing with the clamp GUC32 high 5 cm with screws M6x35, then resting the round profile on the external side of the ladder upright and locking it by inserting the «C» jumper screw inside the upright profile externally to match the fixing holes of the handrails and tighten the bolts.

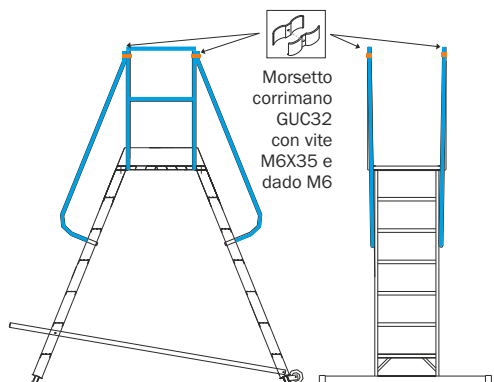

## VERSION LADDER 6088P WITH GROUND FIXING PLATES

*N.B. Before climbing, check all 4 base plates are well fastened to the uprights of the ladder using the specific screws supplied and the flooring using the plugs. .*

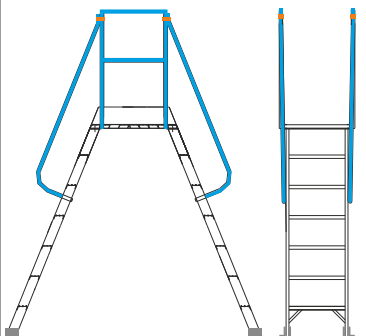

*N.B. Fixed ladder manufactured in compliance with Italian standard Leg. Decree no.81.*

**STANDARDS**

**D.Lgs. 81**



### ARTICLES MADE

Art. **SCA 6088P** / 03-04-05-06-07-08

*N.B. This ladder allows active work because it was tested to compensate for side thrust up to a maximum of 30 kg horizontally. (Before use, check compatibility on the use manual of the work tool or machinery used).*



### ARTICLES MADE

Art. **SCA 6088** / 03-04-05-06-07-08

**STANDARDS**  
**EN 131/3-7**  
NF P93-352  
NF P93-353



**ATTENTION !** - Before using the ladder, read and understand the general provisions outlined from page 2 to 5



## DOUBLE ASCENT LADDER stepped

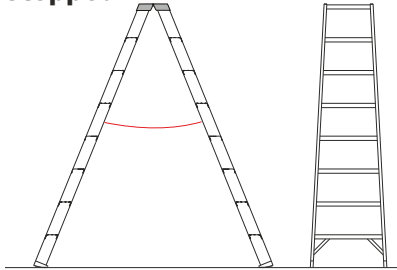

### ARTICLES MADE

Art. **SCA 6015** / 05-06-07-08-09-10-12

1) Open the ladder: Position the ladder on its feet and distance the two ends until the anti-opening safety strap is completely tight (Only for the 12 steps measurement check the spacer bars are completely spread).

**STANDARDS**  
**EN 131/1-2-3**



**ATTENTION:** Before use, check intactness of the strap and, when present, the anti-opening spacer bars.

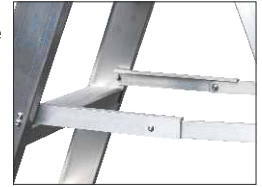

*N.B. When used on the last available step at a height over 2 m the ladder must be anchored to avoid danger of overturning.*

**Last available step** = third last step

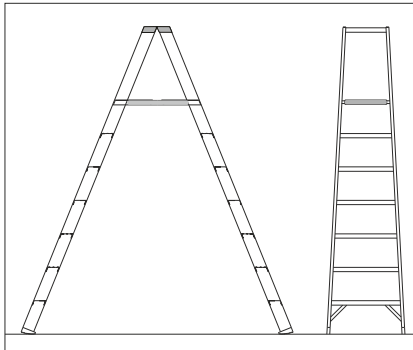

## VERSION LADDER 6025 WITH BRIDGE PLATFORM

Position the ladder on its feet and distance the two ends until the platform is completely open in the horizontal position.

**STANDARDS**  
**D.Lgs. 81**



To close the ladder, slightly lift the hinge at the centre of the platform, then close the ladder again, moving the two ends closer.

*N.B. When used on a platform with a height over 2 m the ladder must be anchored to avoid danger of overturning.*

### ARTICLES MADE

Art. **SCA 6025** / 05-06-08-10

## CONICAL LEANING LADDER stepped

Ladder always ready for use.

*N.B. When used on the last available step at a height over 2 m the ladder must be anchored to avoid danger of slipping.*

### ARTICLES MADE

Art. **SCA 6008** / 07-08-09-10-11-12  
13-14-16-18-20

**Last available step** = third last step

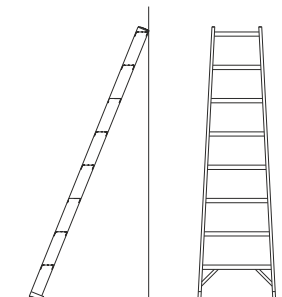

**STANDARDS**  
**EN 131/1-2-3**



### HANDRAIL ACCESSORY

Art. **SCC CSG07-08-09-10-11-12-13-14-16-18-20** Art. **SCA 1969S**

Assemble the two handrails resting the round profile on the external side of the ladder upright and locking it using the «C» jumper screw inside the upright profile outwards to match the fixing holes prepared on the handrails, then insert the washers and tighten the bolts.



**ATTENTION !** - Before using the ladder, read and understand the general provisions outlined from page 2 to 5



## STRAIGHT LEANING LADDER stepped

### 1) Assemble the stabiliser base:

(Only for models with 11 steps upwards)

- Remove the impact-proof safety plugs on the end of the ground support and completely insert the pins inside the upright profiles,
- Insert the specific through-screw on the upright fixing hole and tighten the bolt with manual strength only.

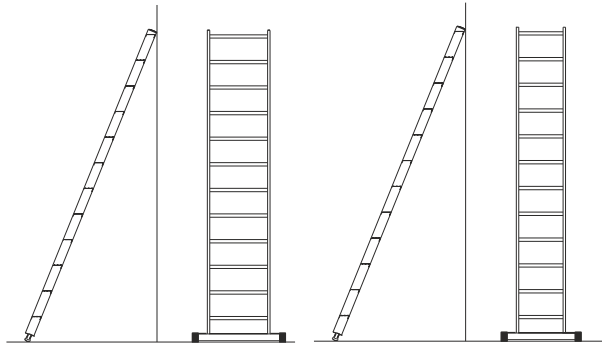
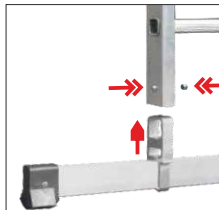

N.B. Articles **SCA 6028N** and **SCA 6048N up to measurement 10** do not have a stabiliser base because it is not required by UNI EN 131.

N.B. When used on the last available step at a height over 2 m the ladder must be anchored to avoid danger of slipping.

**Last available step =**  
fourth last step

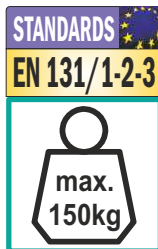

### ARTICLES MADE

Art. **SCA 6028N** / 07-08-09-10-11-12  
13-14-16-18-20

Art. **SCA 6048N** / 07-08-09-10-11-12  
13-14-16-18-20

## VERSION LADDER 6028 and 6048 WITHOUT STABILISER BASE

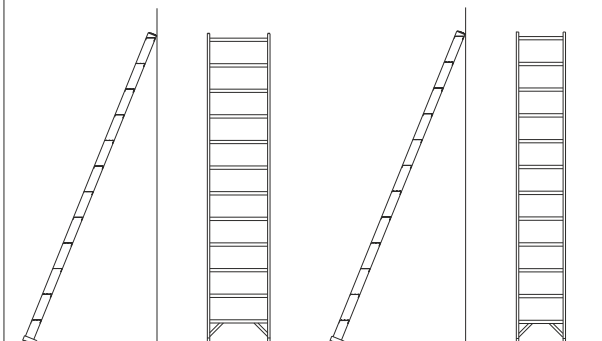

N.B. When used on the last available step at a height over 2 m the ladder must be anchored to avoid danger of slipping.

**Last available step =**  
fourth last step



### ARTICLES MADE

Art. **SCA 6028** / 12-13-14-16-18-20

Art. **SCA 6048** / 12-13-14-16-18-20

## HANDRAIL ACCESSORY

Art. **SCC CSG07-08-09-10-11-12-13-14-16-18-20** Art. **SCA 1969S**

Assemble the two handrails resting the round profile on the external side of the ladder upright and locking it using the «C» jumper screw inside the upright profile outwards to match the fixing holes prepared on the handrails, then insert the washers and tighten the bolts.



## ACCESSORY WALL FIXING PLATE AND HOOKS Art. SCC KTM

Identify the right fixing height of the plate on the wall, positioning the wall rest plate and resting the hooks of the ladder on the horizontal round tube of the plate. Adjust the height of the plate until the steps of the ladder are in the horizontal position, with the help of a level. Then anchor the coupling plate to the wall using the plugs according to the provisions of Leg. Decree no.81.



**ATTENTION !** - Before using the ladder, read and understand the general provisions outlined from page 2 to 5



## STRAIGHT LEANING LADDER WITH FRONT EXIT stepped

### 1) Assemble the stabiliser base: (Only for models over 11 steps)

- Remove the impact-proof safety plugs on the end of the ground support and completely insert the pins inside the upright profiles,
- Insert the specific through-screw on the upright fixing hole and tighten the bolt with manual strength only;

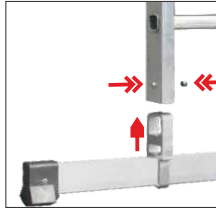

*N.B. The articles SCA 6078N up to measurement 10 do not have a stabiliser base because it is not required by UNI EN 131.*

### 2) Install the handrails

Rest the round profile on the external side of the ladder upright and locking it using the «C» jumper screw inside the upright profile outwards to match the fixing holes prepared on the handrails, then insert the washers and tighten the bolts.

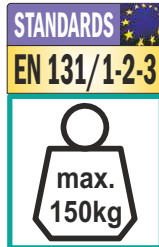

*N.B. When used on the last available step at a height over 2 m the ladder must be anchored to avoid danger of slipping.*

### Legal obligation according to standard Leg. Decree no.81: for ladder use to access raised surfaces

- The ladder must be anchored to the building or the raised surface you intend to access.
- Access to raised surfaces is only permitted if there is appropriate anti-fall protection.
- The minimum distance between the last step of the ladder and the landing surface must not exceed 20 cm.
- The maximum height difference between the last step of the ladder and the landing surface must not exceed 25 cm.

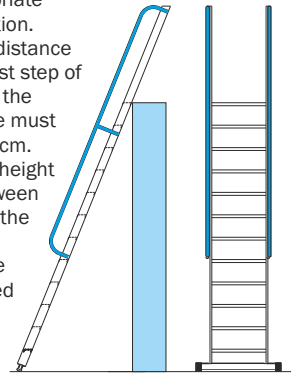

### ARTICLES MADE

Art. SCA 6078N / 05-06-07-08-09-10-11-12-13-14-15-16-17-18-19-20

## VERSION LADDER 6078 WITHOUT STABILISER BASE

It does not add differences or further specifications compared to model SCA 7078N, however Italian standard Leg. Decree no.81 foresees a working load reduced to 100 kg.

*N.B. When used on the last available step at a height over 2 m the ladder must be anchored to avoid danger of slipping.*

### ARTICLES MADE

Art. SCA 6078 / 12-13-14-15-16-17-18-19-20

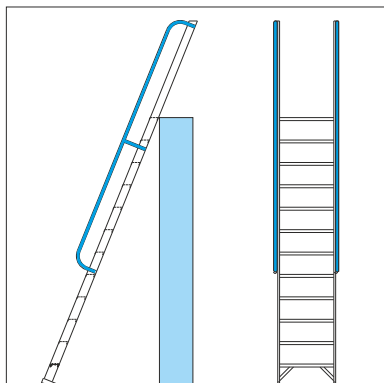

### ACCESSORY WALL FIXING PLATE AND HOOKS Art. SCC KTM

Identify the right fixing height of the plate on the wall, positioning the wall rest plate and resting the hooks of the ladder on the horizontal round tube of the plate. Adjust the height of the plate until the steps of the ladder are in the horizontal position, with the help of a level. Then anchor the coupling plate to the wall using the plugs according to the provisions of Leg. Decree no.81.



**ATTENTION !** - Before using the ladder, read and understand the general provisions outlined from page 2 to 5



## LADDER WITH WORK PLATFORM stepped

### 1) Open the ladder in the use position:

- Position the ladder on its feet and distance the ramp side from the support stand until the platform rests on the cross bar;

### 2) Install the handrails

(Only for models with folding handrails)

- Rotate the frames of the handrails towards the exterior of the ladder up to maximum opening,
- Manually turn the opening locking stops;

(For models with fixed handrails only)

- Rest the round profile on the external side of ladder upright starting from the highest point under the tool tray,
- Insert the «C» jumper screw inside the upright profile towards the outside to meet the fixing holes of the handrails and tighten the bolts.

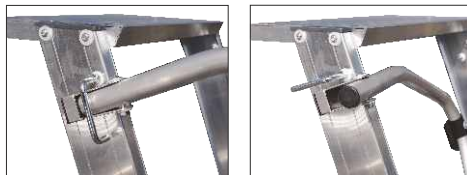

**ATTENTION:** Once on the platform, the railing must be completed, manually securing both the black safety buckles.

**ATTENTION:** Before using model SCA 6080/02, the spring mechanism must be checked of all the self-disabling or self-braking wheels to ensure they are working and obstacle-free.

*N.B. This ladder allows active work because it was tested to compensate for side thrust up to a maximum of 30 kg horizontally. (Before use, check compatibility on the use manual of the work tool used)*

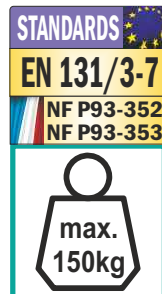
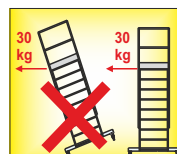
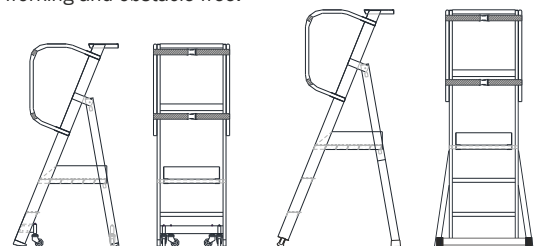

### ARTICLES MADE

Art. **SCA 6080** / 2-3-4-5-6-7-8

## VERSION LADDER 6080 WITH ANTI-OVERTURNING BRACKETS

Before climbing, stabilise the ladder using the telescopic brackets:

- Open the bracket externally,
- Couple the horizontal tie rod to the pawl placed on the tie rod of the ladder,
- Lock the tie rod, rotating the safety disc,
- Remove the internal tube of the telescopic bracket, until it touches the ground,
- Lock the telescopic tube using the stainless steel tie.

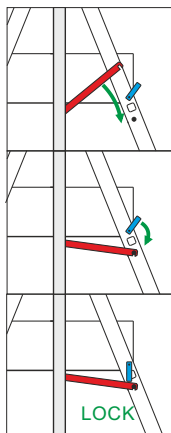
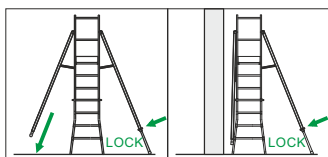

*N.B. Before climbing, ensure correct positioning and locking of both the telescopic brackets.*

*N.B. When working beside a wall, the bracket can be rested near the wall.*

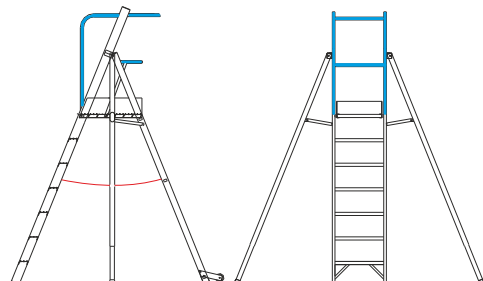

**ATTENZIONE!** - Prima dell'utilizzo della scala leggere attentamente e comprendere le disposizioni generali riportate da pag. n°2 a pag. n°5



## SCALA CON ELEMENTI AD INNESTO ALL'ITALIANA a pioli

### 1) Composizione della scala:

La scala deve essere sempre composta da almeno n° 1 elemento di partenza e da almeno n° 1 elemento terminale, inoltre può essere equipaggiata fino ad un massimo di n° 2 elementi intermedi ma senza mai superare la lunghezza massima di mt. 9,5

- Come primo elemento a terra utilizzare solo elementi di partenza art. SCA V1PA/07-08-09-10
- Come elementi intermedi è possibile utilizzare solo elementi intermedi art. SCA V1IN/06-07-08-09 posizionati uno in successione all'altro
- Come elementi terminali è possibile utilizzare solo elementi terminali art. SCA V1FI/05-06

### 2) Accoppiamento degli elementi scala:

- Stendere a terra gli elementi scala ed unire un elemento con il successivo inserendo il primo gradino dell'elemento superiore nelle staffe a «V» dell'elemento inferiore ed allo stesso tempo inserire le staffe a «V» dell'elemento superiore nei supporti esterni scala dell'elemento inferiore,

- Bloccare il dispositivo anti-sfilo estraendo la linguetta e ruotandola di 90° per inserirla in posizione orizzontale, come da figura.



Anti-sfilo libero



Anti-sfilo bloccato

Scala a 4 elementi



Scala a 3 elementi



Scala a 2 elementi



*N.B. Quando in uso su ultimo gradino disponibile ad altezza superiore a mt. 2 la scala deve essere ancorata o trattenuta da un secondo operatore a terra per evitare il pericolo di scivolamento.*

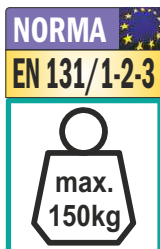

**Ultimo gradino disponibile =** quarto ultimo gradino

3) Attraverso l'aiuto di un secondo operatore sollevare la scala per posizionarla in appoggio a parete

### 4) Aprire la basetta stabilizzatrice

Per entrambi i lati della basetta premere il pulsante di blocco ed estrarre completamente la barra in orizzontale fino all'attivazione del blocco automatico che determina la posizione di utilizzo.

**ATTENZIONE:**  
Prima di salire sulla scala assicurarsi che entrambe le barre siano bloccate alla massima estensione)

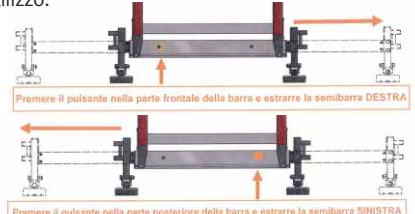

**ATTENZIONE :** La scala deve essere utilizzata sempre e soltanto con la basetta stabilizzatrice completamente aperta. La basetta stabilizzatrice può essere richiusa solo per facilitare le operazioni di trasporto e stoccaggio.

**L'adattamento ad eventuali dislivelli è consentito** attraverso l'uso del piede livellatore:

- Innestare il piede livellatore nel supporto posto al lato del piede snodato quindi bloccare l'aggancio inserendo il perno in acciaio sul pino di bloccaggio,
- Regolare l'altezza del piede livellatore attraverso la rotella posata alla sommità del livellatore



**Il rompi-tratta telescopico** serve per limitare la flessione della scala in uso, realizzando un appoggio intermedio.

Deve essere posizionato ad un'altezza intermedia della scala un uso in corrispondenza di un qualsiasi piolo della scala attraverso l'estremità con morsetto avvolgente posizionato al centro del piolo, mentre l'altra estremità può essere appoggiata a parete o ad un palo attraverso la regolazione della lunghezza con sfilo telescopico fino ad un massimo di mt 1,06



**ATTENZIONE:**  
Le configurazioni scala V100 in uso oltre i mt.8 di sviluppo richiedono l'uso di rompi-tratta intermedio obbligatorio.

**Il dispositivo appoggia-palo** consente l'appoggio scala ad un palo e l'ancoraggio attraverso la fibbia in dotazione. Installare il dispositivo sull'ultimo piolo in posizione centrale mantenendo gli occhielli verso l'alto, quindi ruotare di 90° la piastrina che effettua la chiusura a scatto. La fibbia deve abbracciare il palo e fissata agli occhielli e deve essere stretta fino ad ottenere un'ancoraggio solido.

### ARTICOLI REALIZZATI

Art. SCA V1PA/07-08-09-10

Art. SCA V1IN/06-07-08-09

Art. SCA V1FI/05-06

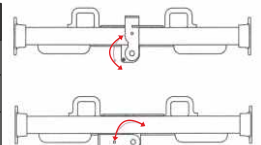



**ATTENTION !** - Before using the ladder, read and understand the general provisions outlined from page 2 to 5



### ACCESSORY BASE WIDENER FOR RUNGED LADDERS **art. SCC STB - For ladders with 1 or 2 or 3 extension element**

The widener guarantees extension of the support base of the ladder in compliance with the European standard EN131/1-2 and represent an alternative to using a stabiliser base:

- Open the nylon strap and widen the bracket,
- Couple the spacer bars on the pin screws,
- For both sides, rotate the anti-detachment safety plates towards the bottom to avoid the spacer bar exiting the screw compartment,
- Release the anti-extension tie and elongate the telescopic foot to the ground, then ensure the tie is locked on the lowest hole.

*N.B. The ladder can only be used if all 4 support feet touch the ground; It is not possible to the base widener to compensate for slopes or side height differences on the ladder.*

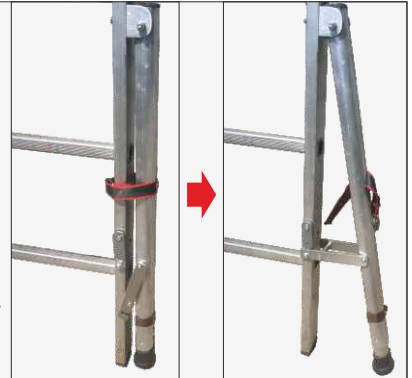

### ACCESSORY TELESCOPIC BASE FOR RUNGED LADDERS **For ladders with 1 or 2 or 3 extension elements equipped with a stabiliser base**

The stabilizing bases must be proportionate to the size of the ladder, therefore the purchase as a spare must be requested based on the specific item of the ladder in use.

The stabilizing bases made for aluminum stairs cannot be applied to fiberglass stairs even if of the same size and vice versa.

#### **HORIZONTAL TELESCOPIC BASE art. BLTD e TELESCOPIC LEVELING BASE art. BLTS**

- For aluminum stairs: Fully insert the pins inside the upright profiles,
- For fiberglass stairs: Fully insert the stair riser inside the base support
- Insert a special through screw on the upright locking hole and tighten the bolt with manual force only,
- Loosen both the black knobs of the base and extend its ends to the maximum length, then re-tighten both knobs by hand.

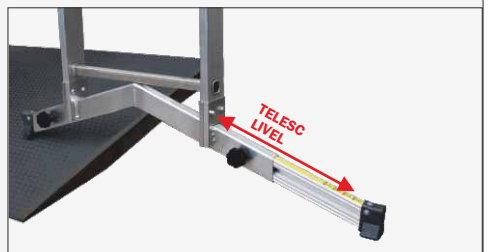
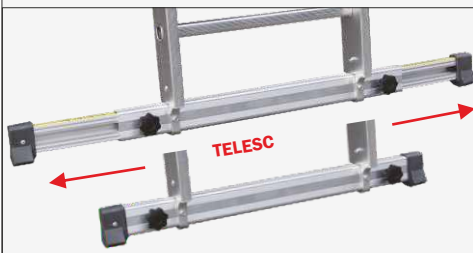

#### **BASE WITH SCREW LEVELERS art. BLIS**

- For aluminum stairs: Fully insert the pins inside the upright profiles,
- For fiberglass stairs: Fully insert the stair riser inside the base support
- Insert a special through screw on the upright locking hole and tighten the bolt with manual force only,
- Position the ladder in place, adjust the levelers to the right height then manually screw the contrast bush towards the base until resistance is met.



**ATTENTION !** - Before using the ladder, read and understand the general provisions outlined from page 2 to 5



### UNIVERSAL LEVELER ACCESSORY FOR RUNG STAIRS - art. SCC LR

For ladders with 1 or 2 or 3 extension elements not equipped with a stabiliser base

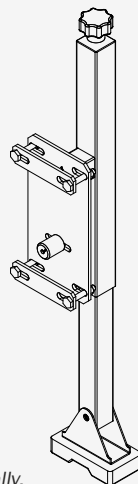
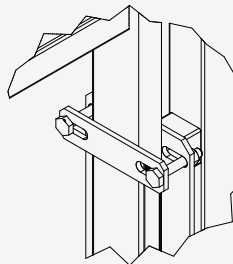
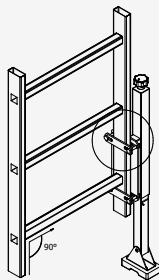

- Remove the two discs and the 4 bolts,
- Bring the leveller beside the ladder and insert the pin (2) in the first lower rung of the ladder,
- Using the 6 keys, tie the uprights of the ladder,
- Adjust the height with the knob until the ladder is level,
- Check perpendicularity with a level or plumb line.

*N.B. It is forbidden to extract the telescopic internal tube over the «STOP» line, indicated internally.*

### ACCESSORY CROSS SECTION ON SECTION 1 - Art. SCC RT - For ladders with 2 or 3 extension elements extending over 8.0 m NOT CERTIFIED to European standard

**Leg. Decree no.81 - Art. 113-6, par. b:** Work ladders over 8.0 metres must be equipped with a cross section to reduce the deflection (exemption is permitted of this article only for ladders compliant with EN131/1-2).

#### ASSEMBLY INSTRUCTIONS

- 1) Dismantle the pulley-holder (only for ladders with a rope),
- 2) insert the threaded pin in the last rung of first lower element,
- 3) Tighten the support tubes of the threaded pin,
- 4) Re-assemble the pulley-holder (only for ladders with a rope).

#### USE INSTRUCTIONS

- Lean the ladder against the wall at the desired height and in compliance with the ideal inclination between 65° and 75° ,
- Rest the feet of the cross section on the ground,
- Climb on the ladder having secured it against the slide or holding it with the help of another operator on the ground,
- Comply with the instructions in this manual and the legal safety provisions in force.

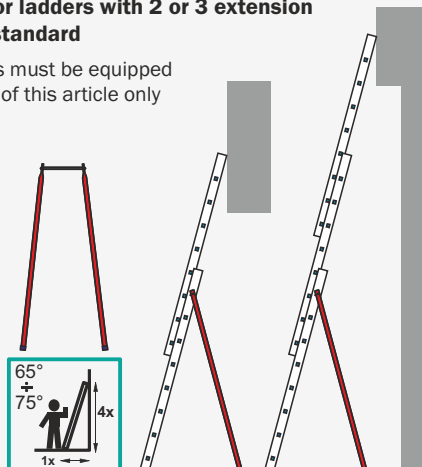

# Reference Standards

From legislative Decree no. 81 dated April 9, 2008

## Art. 111. Employer obligations in using equipment for work above ground

1. The employer, when temporary work above ground cannot be performed in safety conditions and adequate ergonomic conditions from a place suited for this purpose, selects the most appropriate work equipment to guarantee and maintain safe work conditions.. <omissis>
3. The employer ensures that a ladder is only used as an above ground workplace when the use of other work equipment considered safer is not justified due to the limited risk level and short-term use or site features that cannot be modified.. <omissis>
5. The employer, according to the type of work equipment adopted based on the previous points, identifies measures to minimise worker risks, intrinsic to the equipment in question, installing, where necessary, fall protection devices. These devices must have a configuration and resistance to avoid or stop falls from above ground work sites and prevent, where possible, any worker injuries. Group protection devices against falls may only include interruptions in points where there are ladders or rungs.
7. The employer only performs temporary work above ground if weather conditions do not put workers' safety and health in jeopardy.
8. The employer also prohibits workers assigned to above ground work from drinking or administering alcohol or hard liquor.

## Art. 113. Ladders

3. The simple ladders (carried by hand) must be manufactured by proper material for their use, they must be strong enough as a whole and in every single element and they must have proper dimensions for their use... <omissis>  
They must have also:
  - a) non-slip devices on the top and on the bottom of the two uprights.
  - b) Holding hooks or non-slip elements on the top parts, when it is necessary to fix the stability of the ladder
4. For ladders that are equipped with holding devices on the top, even if sliding on rails, the safety devices stated in the letters a) and b) paragraph 3 are not required.<omissis>
5. When the use of the ladder, due to its height or to other reason, causes danger of instability, it must be insured or hold to the foot by another person.
6. The employer shall ensure that the rung ladders are placed in a proper way so that to ensure the stability during their use and following these points: a) the portable rung ladders must be placed on a fixed and strong support. This support must have proper dimensions so that to ensure the horizontal position of the rungs; b) the rung hanging ladders must be fixed in a safety way and, rope ladders a part, in order to avoid any kind of change of position and oscillating movements; c) by using a portable rung ladder, the sliding foot must be prevented by fixing the upper or the bottom part of the uprights, or by using any other non-slip device or any other efficient solution; d) the access rung ladders must be long enough in order to overpass the access level unless there is another device that can grant the safety access; e) the rung ladders composed by different elements must be used so that every element is well fixed; f) the mobile rung ladders must be fixed permanently before to be used.
7. The employers ensures the rung ladders are used so that the operator has in every moment a safety handling support. In particular by carrying a weight on a rung ladder, the operator must always have a safety handle.
8. To use the portable extendable ladder of two or more elements (like the Italian version or similar), in addition to what stated into the paragraph n.3, it is compulsory to follow these points:
  - a) the extended length must not be more than 15mt, except for particular situation and in case the top part of the ladder must be ensured to fixed supports.
  - b) The extended ladders, that are longer than 8, must have the section divider in order to reduce the swaying movement of the ladder.
  - c) No employer must be on the ladder during the lateral movement of the ladder itself
  - d) During the execution of the work, another ground person must pay attention to the ladder.
9. The double ladders must no overpass the 5 mt of length and they must be equipped with chain or some other device that prevent the opening of the ladder over the safety limit.
10. It is allowed the dispensation of manufacturing aspect for the paragraph 3,8 and 8 for the portable ladders that are in compliance with the attachment XX (Cfr. En131).

**Please note: by working on ladder at more than 2 mt of height, it is advisable to be ensured against falls (for example by adopting Italian Presidential Decree Ce harness secured to fixed elements).**

# DECLARATION OF CONFORMITY

We declare that:

All ladders produced by us, including that accompanying this booklet, are manufactured in compliance with the Italian Presidential Decree n. 81 dd. 08/04/2008.

We also declare that to remain in order with previously stated standard, the use instructions labelled on the ladder, that is the warnings described in this booklet, must be strictly adhered to.



FRIGERIO CARPENTERIE S.p.A.  
Il Legale rappresentante

Orio Al Serio, 01 January 2020

It is hereby declared that the ladder models listed below are tested and certified according to:

- **European standard EN 131, part 1-2-3,**
- or **European standard EN 131, part 4** when specified,
- or in compliance with **European standard EN 131, part 7** or **NFP093 352/53** when specified,

It is also declared that each ladder model in fibreglass listed below is certified according to **European standard EN 50528** and guarantees electrical insulation at low voltage to 1000V A.C. and up to 1500V D.C.

(refer to the identification sticker and serial number on the ladder)

Ladder Model	Description	Certificate No.	Issued by	On date
SCA 1970 / 12	All purpose telescopic rung ladder (EN 131-4)	D 019700 0026	TÜV SUD (TO)	13/07/2021
SCA 1970 / 14-16-18	All purpose telescopic rung ladder (EN 131-4 with SCC BA1970)	D 019700 0026	TÜV SUD (TO)	13/07/2021
SCA 1970 / 18R-20R-22R	All purpose telescopic rung ladder (EN 131-4 with SCC BA1970)	D 019700 0026	TÜV SUD (TO)	13/07/2021
SCA 1970 / 24E	All purpose telescopic rung ladder (EN 131-4 with SCC BA1970)	D 019700 0026	TÜV SUD (TO)	13/07/2021
SCA 6026-6026T (all measurements)	Standing ladder one ascent with platform	D 18 05 19700 020	TÜV SUD (TO)	11/05/2018
SCA 6040-6040T (all measurements)	Standing ladder one ascent with platform	D 18 05 19700 020	TÜV SUD (TO)	11/05/2018
SCA 6046 (all measurements)	Standing ladder one ascent with platform	D 18 05 19700 020	TÜV SUD (TO)	11/05/2018
SCA 6016 (all measurements)	Standing ladder one ascent	D 18 05 19700 020	TÜV SUD (TO)	11/05/2018
SCA 6015 (all measurements)	Standing ladder double ascent	D 18 05 19700 020	TÜV SUD (TO)	11/05/2018
SCA 6087 (all measurements)	Ladder with platform (EN 131-7)	2013/247/18	POLITECNICO (MI)	18/03/2015
SCA 6088 (all measurements)	Ladder with platform double ascent (EN 131-7)	2013/246/1	POLITECNICO (MI)	19/03/2015
SCA 6085 (all measurements)	Ladder with platform (EN 131-7)	2014/491/1	POLITECNICO (MI)	22/05/2014
SCA 1980 (all measurements)	Runged ladder with platform (EN 131-7)	2014/913/1	POLITECNICO (MI)	28/04/2014
SCA 680N (all measurements)	Leaning rung ladder - one element	D 18 05 19700 022	TÜV SUD (TO)	11/05/2018
SCA 6008 (all measurements)	Conical leaning ladder	D 18 05 19700 023	TÜV SUD (TO)	11/05/2018
SCA 6028N (all measurements)	Wide leaning ladder 450	D 18 05 19700 023	TÜV SUD (TO)	11/05/2018
SCA 6048N (all measurements)	Wide leaning ladder 600	D 18 05 19700 023	TÜV SUD (TO)	11/05/2018
SCA 6078N (all measurements)	Leaning ladder with front exit	D 18 05 19700 023	TÜV SUD (TO)	11/05/2018
SCA 6082N (all measurements)	Folding ladder with platform	D 18 05 19700 020	TÜV SUD (TO)	11/05/2018
SCA 3043 / 3-4	Articulated and folding, all purpose rung ladder	VA MES 15 02 049	TÜV SUD (TO)	23/07/2015
SCA 3045Z / 6-7-8-10-12-14-16	All purpose rung ladder - two elements combination use	D 18 05 19700 024	TÜV SUD (TO)	11/05/2018
SCA 3045 / 6-7-8-10-12-14-16	All purpose rung ladder - two elements	D 18 05 19700 024	TÜV SUD (TO)	11/05/2018
SCA 3047Z / 6-7-8-9-10-11	All purpose rung ladder - three elements combination use	D 18 05 19700 024	TÜV SUD (TO)	11/05/2018
SCA 3047 / 6-7-8-9-10-11-12-14	All purpose rung ladder - three elements	D 18 05 19700 024	TÜV SUD (TO)	11/05/2018
SCA 3046N / 6-7-8-10-12-14	Leaning rung ladder - two elements	D 18 05 19700 021	TÜV SUD (TO)	11/05/2018
SCA 5048N / 8-10-12-14	Leaning rung ladder - three elements	D 18 05 19700 021	TÜV SUD (TO)	11/05/2018
SCA 3051N / 12-14-16-18	Leaning rung ladder - two elements + rope	D 18 05 19700 021	TÜV SUD (TO)	11/05/2018
SCA 3060N / 10-12-14-16	Leaning rung ladder - three elements + rope	D 18 05 19700 021	TÜV SUD (TO)	11/05/2018
SCA 1959N / 14-16-18	Leaning rung ladder - three elements + winch	D 18 05 19700 021	TÜV SUD (TO)	11/05/2018
SCA V026 / 4-5-6-7-8-9-10-11-12	Standing ladder one ascent with platform	D 18 05 19700 020	TÜV SUD (TO)	11/05/2018
SCA V015 / 4-5-6-7-8-9-10-11-12-14	Standing ladder double ascent	D 18 05 19700 020	TÜV SUD (TO)	11/05/2018
SCA V016 / 4-5-6-7-8-9-10-11-12	Standing ladder one ascent	D 18 05 19700 020	TÜV SUD (TO)	11/05/2018
SCA V080N / 6-7-8-9-10-11-12-13-14	Leaning rung ladder - one element	D 18 05 19700 022	TÜV SUD (TO)	11/05/2018
SCA V047Z / 6-7-8-9-10-11	All purpose rung ladder - three elements combination use	D 18 05 19700 024	TÜV SUD (TO)	11/05/2018
SCA V047 / 6-7-8-9-10-11-12-13-14	Scala a pioli multiuso - tre elementi	D 18 05 19700 024	TÜV SUD (TO)	11/05/2018
SCA V045Z / 6-7-8-9-10-12-14	All purpose rung ladder - two elements combination use	D 18 05 19700 024	TÜV SUD (TO)	11/05/2018
SCA V045 / 6-7-8-9-10-12-14-16	All purpose rung ladder - two elements	D 18 05 19700 024	TÜV SUD (TO)	11/05/2018
SCA V051N / 12-14-16-18	Leaning rung ladder - two elements + rope	D 18 05 19700 021	TÜV SUD (TO)	11/05/2018
SCA 3051NV / 12-14-16-18	Leaning rung ladder - two elements + rope	D 18 05 19700 021	TÜV SUD (TO)	11/05/2018
SCA V060N / 10-12-14-16	Leaning rung ladder - three elements + rope	D 18 05 19700 021	TÜV SUD (TO)	11/05/2018
SCA 3060NV / 10-12-14-16	Leaning rung ladder - three elements + rope	D 18 05 19700 021	TÜV SUD (TO)	11/05/2018
SCA V100	Leaning rung ladder	on demand	on demand	on demand

Ladder Model	Description	Conformity
SCA 6080 / 2-3-4-5-6-7-8	Anti-overturning folding ladder with platform	EN 131-7
SCA 6082C / 4-5-6-7-8-9-10	Anti-overturning folding ladder with platform	EN 131-7
SCA 6083A / 4-5-6-7-8-9-10-12-14	Anti-overturning folding ladder with platform	EN 131-7



The «CE» mark cannot be applied to ladders and scaffolds, since they are not covered by the Machinery Directive.

**Edition March 2025**  
All rights reserved