

# INSTRUCTIONS MANUAL

## INDUSTRIAL LADDERS and AERIAL LADDERS

### Guarantee and insurance certificate:

The undersigned company Frigerio Carpenterie S.p.A. guarantees for the ladder specified below and for a period of 10 years or a period of 5 years, starting from the purchase date, replacement or repair free of charge for parts resulting as defective due to materials or machining; it also insures against any damages caused to property or people caused by the same parts if ascertained as having left the production plant in defective condition.

The following are not included in this guarantee:

- defects or breakages and all consequences caused by misuse and/or lack of compliance, even if only in part, with that indicated in the instructions and/or that prescribed by the specific current standards.
- Damage caused by wear or atmospheric agents
- Interventions for presumed defects or convenience inspections

This guarantee is not valid in the case of mishandling or repairs carried out by persons not authorised by Frigerio Carpenterie S.p.A. or if carried out using non-original spare parts.

Ladder model: \_\_\_\_\_ Date of purchase: \_\_\_\_\_

Serial Number, if any -  
Manufacture month/year:

Stamp and signature  
of Retailer:



ICONTENT	
REASONS FOR ACCIDENTS - MARKING AND STICKERS	pag. 2
ADHESIVES AND PICTOGRAMS	pag. 3
GENERAL USE WARNINGS	pag. 4
MAINTENANCE and CONTROLS and TRAINING	pag. 5
• 7060 - 7080	pag. 6
• 7100	pag. 7
• 7760 - 7780	pag. 8
• 7199	pag. 10
• 7260 - 7280	pag. 11
• 7366 - 7368	pag. 12
• 7346 - 7348	pag. 13
• 5056	pag. 14
• 1913	pag. 16
• AV60 - AV80	pag. 18
• ITALIAN LEGISLATION Leg. Decree no.81 and DECLARATION OF CONFORMITY	pag. 19
• STING AND CONFORMITY	pag. 20

This manual is based on the provisions of Leg. Decree no.81 and pursuant to standard EN131-3 for products certified according to requirements: EN131-1 (terms, types and functional dimensions of leaning ladders and/or double ladders), EN131-2 (requirements, testing and marking for leaning ladders and/or double ladders), EN131-7 or NF P093-352/53 (anti-overturning platform ladder).



## REASONS FOR ACCIDENTS

The following is a non-exhaustive list of the dangers and examples of frequent causes of accidents which can occur when using the ladders and on which the information contained in this manual is based.

### Loss of stability:

- Incorrect position of the ladder (for example: incorrect angle of a leaning ladder or incomplete opening of a double ladder).
- Sliding outwards from the base (for example: the bottom of the ladder moves away from the wall).
- Sliding sideways, falling sideways and overturning (for example: protruding or due to the fragility of the upper contact surface).
- Condition of the ladder (for example: non-slip feet missing).
- Climbing down the ladder or climbing up to a height when the ladder is not secure.
- Ground conditions (for example: if the ground is soft or unstable, on slopes, slippery surfaces or soiled solid surfaces).
- Poor climatic conditions (for example: wind).
- Collision with the ladder (for example: by a vehicle or a door).
- Incorrect choice of ladder (for example: ladder too short or not suitable for the specific use).

### Movement:

- Transfer of the ladder to the work position.
- Assembly and dismantling of the ladder.
- Transport of objects on the ladder.

## MARKING and STICKERS

Read all the data carefully on the ladder stickers, paying particular attention to the maximum working load and the use height and the specific instructions of the product purchased by you on the following pages.

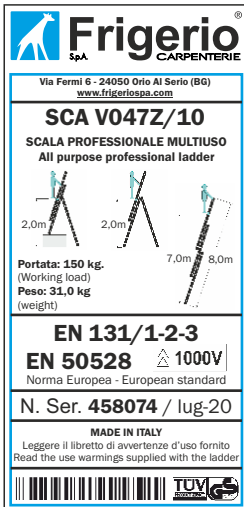

**Frigerio**  
S.p.A. CARPENTERIE

Via Fermi 6 - 24050 Orto Al Serio (BG)  
www.frigeriospa.com

**SCA V047Z/10**  
SCALA PROFESSIONALE MULTIUSO  
All purpose professional ladder



2.0m 2.0m 7.0m 8.0m

Portata: 150 kg.  
(Working load)  
Peso: 31,0 kg  
(weight)

**EN 131/1-2-3**  
**EN 50528**   
Norma Europea - European standard

N. Ser. **458074** / lug-20

MADE IN ITALY  
Leggere il libretto di avvertenze d'uso fornito  
Read the use warnings supplied with the ladder



**Frigerio**  
S.p.A. CARPENTERIE

Via Fermi 6 - 24050 Orto Al Serio (BG)  
www.frigeriospa.com

**SCA 6026/08**  
SCALA PROFESSIONALE CAVALLETTO  
Professional trestle ladder



1.8m

Portata: 150 kg.  
(Working load)  
Peso: 10,0 kg  
(weight)

**EN 131/1-2-3**  
Norma Europea - European standard

N. Ser. **435560** / mag-20

MADE IN ITALY  
Leggere il libretto di avvertenze d'uso fornito  
Read the use warnings supplied with the ladder



**Frigerio**  
S.p.A. CARPENTERIE

Via Fermi 6 - 24050 Orto Al Serio (BG)  
www.frigeriospa.com

1000V

Non usare, non maneggiare, né portare il ladder di fronte a conduttori di grandi dimensioni, conduttori nudi, o conduttori di tensione elevata. Questo spazio protetto è un'area riservata a operatori e personale qualificato. Non avvicinarsi. Non toccare. Non usare. Non maneggiare. Non portare il ladder di fronte a conduttori di grandi dimensioni, conduttori nudi, o conduttori di tensione elevata. This protected area is reserved for operators and qualified personnel. Do not approach. Do not touch. Do not use. Do not handle. Do not carry the ladder in front of large conductors, bare conductors, or high voltage conductors.

### Slipping, tripping, falling operator:

- Unsuitable footwear.
- Soiled rungs or steps.
- Unsafe actions by the user (for example: climbing up the ladder two rungs at a time or sliding down the upright profiles).

### Structural failure of the ladder:

- Unsuitable footwear.
- Ladder conditions (for example: upright profiles, hinges or steps damaged, worn).
- Ladder overloaded.

### Electrical hazards:

- Inevitable operations on live parts (for example: searching for faults).
- Positioning of the ladder too near live electrical equipment (for example: overhead electricity lines).
- Damage to electrical equipment (for example: protective coverings and insulation) caused by the ladders.
- Incorrect choice of type of ladder for electrical works (for example: use of non-insulating ladders or not equipped with electrical isolation certification or equipped with insulating capacity differing from the specific use on-site).

### Identification of the ladder:

If communicating with the manufacturer or the dealer, state the product code or, if necessary, the serial number and year of manufacture. .



**Frigerio**  
S.p.A. CARPENTERIE

Via Fermi 6 - 24050 Orto Al Serio (BG)  
www.frigeriospa.com

**SCA A CAVALLETTO**  
STANDING LADDER  
ECHELLE DOUBLE



MAX. 1



MAX. 1



ULTIMO GRADINO UTILIZZABILE  
Vedi manuale istruzioni d'uso  
LAST USEFUL STEPS  
See instruction manual  
DERNIERE ECHELLE UTILISABLE  
voir le manuel d'instructions

**Frigerio**  
www.frigeriospa.com



**Frigerio**  
S.p.A. CARPENTERIE

Via Fermi 6 - 24050 Orto Al Serio (BG)  
www.frigeriospa.com

**SCALA D'APPoggio**  
LEANING LADDER  
ECHELLE EN APPUI



65°-75°



MAX. 1



NO STEP



MAX. 1



ULTIMO GRADINO UTILIZZABILE  
Vedi manuale istruzioni d'uso  
LAST USEFUL STEPS  
See instruction manual  
DERNIERE ECHELLE UTILISABLE  
voir le manuel d'instructions

**Frigerio**  
www.frigeriospa.com

## ADHESIVES AND PICTOGRAMS

The basic information is outlined in a clearly visible format on the adhesive of each ladder produced.

The square pictograms with a green or blue border illustrate a positive action to follow while the round pictograms with a red border illustrate a forbidden action.

*N.B. If the adhesive is damaged or very worn, you can inform our office to request a new one*

Secure the base and top of the ladder



Minimum extension of the ladder over the arrival point

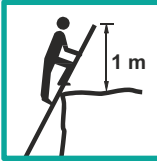
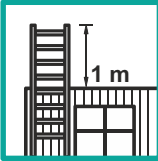

Read the instructions



Maximum permitted load



Correct support angle

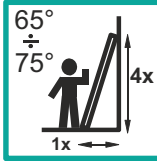

Visual inspection before use

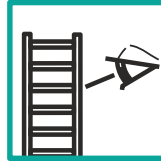

Maximum number of users on ladder



Check intactness of the ladder support feet



Ensure the ladder is fully open

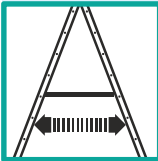

Ensure all the safety devices against accidental opening and closure are activated and locked

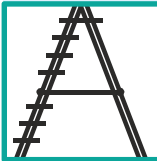

Use the ladder with the correct orientation



Do not stand on top step



Position and use the ladder on flat ground



Do not use the ladder as a bridge



Do not hang over it sideways and keep the centre of gravity at the centre of the ladder



Pay attention to electrical hazards when using and transporting the ladder



Ensure there is no dirt, water or oil on the ground



Position and use the ladder on solid ground



Ensure the top of the ladder is correctly positioned



Do not climb down the sides of the ladder to access raised surfaces



Turn towards the ladder both when climbing up and down it



Access to the climbing ramp is permitted to one person at a time



## GENERAL USE WARNINGS

### Before use:

- Ensure you are physically fit enough to use the ladder. Certain medical conditions, use of medicine, or abuse of alcohol or drugs could make use of the ladder unsafe
- If the ladder is transported on a roof rack or a truck, ensure it is correctly positioned to avoid damage;
- Inspect the ladder after delivery and before first use to check the conditions and operation of all its parts;
- Visually inspect the ladder is not damaged and that it can be used safely at the start of each working day;
- For professional users, regular periodic inspection is required, at most every 100 hours of use;
- Ensure the ladder is suitable for the specific use;
- Do not use damaged ladders;
- Remove every trace of dirt, such as fresh paint, mud, oil or snow from the ladder;
- Before using a ladder in the workplace, a risk assessment should be carried out in compliance with legislation in the country of use.

### Positioning and assembly of the ladder:

- The ladder must be assembled in the correct position, i.e. with the correct angle for a leaning ladder (between 65° and 75° with a ratio of 1:4) and completely open for a double ladder; If the ladder is equipped with flat or deep steps over 5 cm, the ladder should be positioned to keep the steps in the horizontal position
- The anti-closure and anti-opening safety devices if planned, must be completely blocked before use;
- The ladder must be on a flat, horizontal and non-moving base;
- A leaning ladder must rest against a non-fragile surface and be secured before use, for example tying it or using a suitable stabilisation device
- The position of the ladder must never be changed from above;
- When the ladder is positioned, remember the risk of collision with it, for example, with pedestrians, vehicles or doors;
- Identify all the electrical risks in the work area, such as lines or other exposed electrical equipment;
- The ladder must rest on its feet and not on the rungs or steps;
- The ladder must not be positioned on slippery surfaces (such as ice, polished surfaces or very soiled solid surfaces), unless suitable measures are taken to avoid the ladder slipping or ensure sufficient cleaning of the dirty surface.

### Using the ladder:

- Do not exceed the total maximum load for the type of ladder;
- Do not hang off the ladder; the user's belt buckle should be inside the upright on both feet on the same step/rung during the entire operation;
- Do not leave the ladder to access another location at a height without additional safety, such as a tying system or suitable stabilisation device; do not use double ladders to access another level;
- Do not stay on the three highest steps/rungs of a leaning ladder;
- Do not stay on the two highest steps/rungs of the double ladder without a platform and body-guard;
- Do not stay on the four highest steps/rungs of a double ladder with cantilevered section or however not beyond the top of the scissors/stand/intersection of the round sections. Use the cantilevered section as a handhold only;
- The ladders should only be used for light and short works;
- Use non-conductive ladders to carry out works on live electrical parts;
- Do not use the ladder outdoors, in bad weather conditions such as strong wind;
- Take precautions to avoid children playing on the ladder;
- Secure the doors (except the fire-escape exits) and the windows, where possible, in the work area;
- Face the ladder when climbing up and down;
- Keep a safe grip on the ladder when climbing up and down;
- Do not use the ladder as a bridge;
- Wear suitable footwear to climb on the ladder;
- Do not spend long periods of time on the ladder without regular breaks (tiredness can contribute to risk);
- Leaning ladders used to access a higher level must extend by at least 1 metre over the arrival point, as well as be anchored to a fixed part as outlined in Legislative Decree no.81 from 2008;
- The equipment transported on the ladder must be light and manageable;
- Avoid excess side loads, for example lifting packs that are too heavy;
- Avoid operations requiring application of side thrust such as solid material perforation (bricks-cement) on leaning and double ladders, if not compliant with standard EN131-7 and however within the terms planned by the standard (not over 30 kg, horizontally);
- Maintain a support while using the ladder, or implement the safety precautions if this is not possible;
- The length of the ladder must not be increased by tying together multiple ladders or fastening extensions on the uprights;
- Do not use a double ladder as a support (so-called scissors or stand).

### Ladder demolition:

- Ladders must not be disposed of in the environment, but delivered to the specific, authorised collection centres.

### Repair and cleaning:

- Repairs must only be carried out by competent staff, compiling the following data sheet. Contact the Frigerio dealers or directly contact Frigerio Carpenterie S.p.A. on 035-4242311.
- Ladders must be cleaned with a damp cloth using water or alcohol.

Date	Intervention description	Technical signature

## MAINTENANCE and CONTROLS

Our aluminium or fibreglass ladders do not need any particular maintenance or periodic servicing, but you are recommended to take note of the general warnings in this manual and the specific use instruction for the model used, described on the following pages and keep the ladders away from atmospheric agents, oxidants and corrosive substances. You are also advised to safeguard ladders to avoid improper use. The manufacturer cannot be held in any way liable for damage to people or property which can derive from improper use of the ladders and total or partial non-compliance with the standards outlined in this manual and those in force, or non-compliance with periodic controls or maintenance against possible damage caused by use or atmospheric agents.

For this reason, AT LEAST EVERY 100 HOURS AND BEFORE EACH USE, CAREFULLY CHECK THE ELEMENTS ARE INTACT and, if necessary, signal any deficiencies found to your manager (Art. 18-9-20 Leg. Decree no.81: worker and supervisor obligations) and comply with the provisions of safety legislation.

Date of inspection day/month/year	Ladder model article code	Components checked yes/no	Components cleaned yes/no	Rungs and uprights intact yes/no	Feet intact yes/no	Anti-extension and anti-opening devices intact yes/no	Welding intact yes/no	No rust yes/no	Stickers intact yes/no

## USER TRAINING and INFORMATION

In compliance with the provisions of Art. 36, 37 and 73 of Legislative Decree no.81 on 9 April 2008, I declare to have consulted the manual outlining the instructions for use and maintenance of the ladder and I am therefore informed and trained in the health and safety risks, on the safety measures and the hazards relating to its use.

Date	Operator's name and surname	Operator's signature	Company stamp and signature

**ATTENTION !** - Before using the ladder, read and understand the general provisions outlined from page 2 to 5



## INDUSTRIAL STOOL WITH PLATFORM

- 1) Assemble the stool by orienting the landing as shown in the figure to the side and join it to the climbing ramp and the stand with the M8x50 screws inserted from top to bottom at the holes provided on the fixing plates, then tighten the bolts and washers supplied;
- 2) Install the spacer rods on the outside of the upright profiles with the M8x60 screws inserted from the outside to the inside using the holes provided, then tighten the bolts and washers supplied.

Note: Tighten the screws with manual force alone or similar devices to prevent deformation of the aluminium profiles.

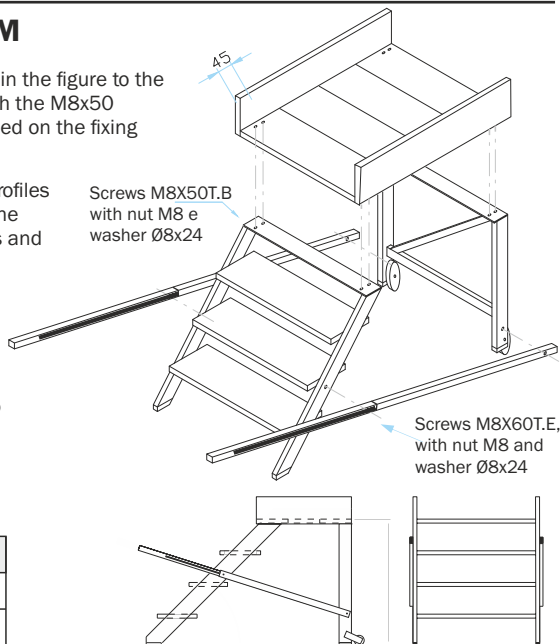

**STANDARDS**  
**D.Lgs. 81**



max.  
200kg

**WARNING:** When used for access to raised floors, the stool must be anchored to the ground using at least 2 base plates art. SCC PDAI.

### ARTICLES MADE

Art. **SCA 7060** / 02-03-04-05

Art. **SCA 7080** / 02-03-04-05

### VERSION STOOL 7060-7080 WITH BASIC PLATES art. SCC PDAI

In order to comply with the European standard EN 14183 the stool must be equipped with at least 4 base plates art. SCC PDAI.

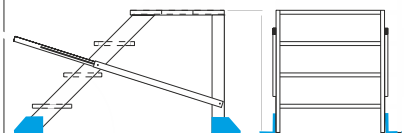

The base plates increase the support base and improve the stability of the stool.



**STANDARDS**  
**EN 14183**



max.  
150kg

### VERSION STOOL 7060-7080 WITH HANDRAILS, PARAPETS and STABILIZER BASE

This ladder allows active work because it has been tested to compensate for lateral thrusts up to a maximum of horizontal 30 kg. (Before use, check the compatibility in the user manual of the work tool used).

#### WARNINGS:

- The EN131-7 standard is guaranteed only when the stool is equipped with a stabilizing base as well as parapets and handrails on all sides
- The side handrail is supplied only combined with the side railing
- The front railing is supplied only combined with the side railings
- The anti-overturning stabilizing base is mandatory when the stool is equipped with handrails and parapets even if not complete

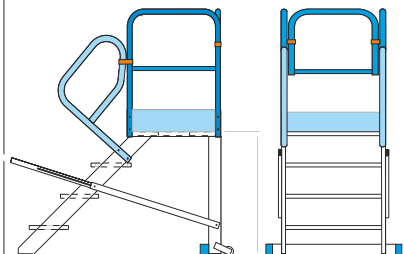



**STANDARDS**  
**EN 131/3-7**

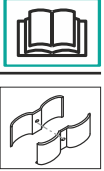

max.  
150kg

**ATTENTION !** - Before using the ladder, read and understand the general provisions outlined from page 2 to 5



## INDUSTRIAL PODIUM LADDER WITH WORKING PLATFORM

- 1) Assemble the ladder by orienting the landing as shown in the figure to the side and join it to the ascent ramp and the stand with the M8x50 screws inserted from top to bottom at the holes provided on the fixing plates, then tighten the bolts and washers supplied;
- 2) Install the spacer rods on the outside of the upright profiles with the M8x60 screws inserted from the outside to the inside using the holes provided, then tighten the bolts and washers supplied;
- 3) Install the side railings outside the upright profiles of the landing with the M6x75 screws inserted from the inside of the ladder towards the outside and the front railing between the two side railings at the same height using the GUC42 hooks and relevant M6x35 screws and tighten the bolts and washers;
- 4) Install the handrails as shown in the figure, placing the round profile on the outer side of the ladder upright and lock it by inserting the "C" U-bolt screw from the inside of the ladder towards the outside to meet the fixing holes on the round profile, then hook the upper end of the frame to the round profile of the upper handrail frame using the GUC42 hooks and relevant M6x35 screws and tighten the bolts and washers (For sizes over 7 steps it is necessary to install several handrail frames in succession).

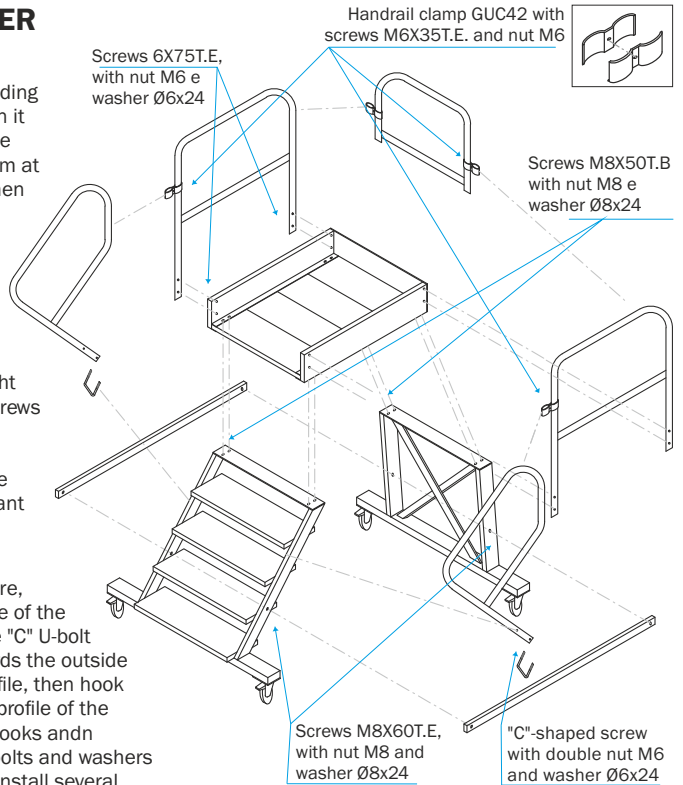

Note: Both handrails must always be installed in order to comply with the European standard EN131 or Italian standard D.Lgs.n°81

Note: Tighten the screws with manual force alone or similar devices to prevent deformation of the aluminium profiles.



Note: Before climbing the ladder, check that each wheel is properly braked: The brake is activated and deactivated by acting on the front tab with the foot protected by a work shoe. N.B. Questa scala

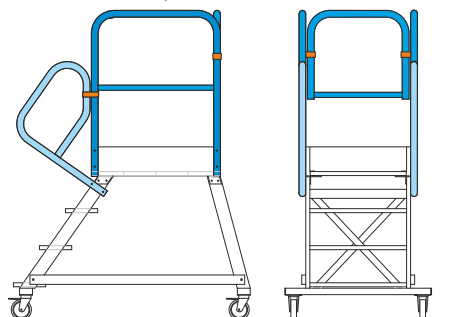

This ladder allows active work because it has been tested to compensate for lateral thrusts up to a maximum of horizontal 30 kg. (Before use, check the compatibility in the user manual of the work tool used).

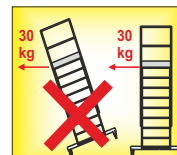

### ARTICLES MADE

Art. SCA 7100 / 03-04-05-06-07-08

<b>STANDARDS</b>
<b>EN 131/3-7</b>
<b>NF P93-352</b>
<b>NF P93-353</b>
<b>max. 150kg</b>

**ATTENTION !** - Before using the ladder, read and understand the general provisions outlined from page 2 to 5



## INDUSTRIAL PODIUM LADDER WITH WORKING PLATFORM

- 1) Assemble the ladder by orienting the landing as shown in the figure to the side and join it to the climbing ramp and the stand with the M8x50 screws inserted from top to bottom at the holes provided on the fixing plates, then tighten the bolts and washers supplied;
- 2) Install the horizontal spacer rods (and diagonal for sizes over 7 steps) on the outside of the upright profiles with the M8x60 screws inserted from the outside to the inside using the holes provided, then tighten the bolts and washers supplied;
- 3) Install the side railings outside the uprights of the landing with the M6x75 screws inserted from the inside of the ladder towards the outside and the front railing between the two side railings at the same height using the GUC42 hooks and relevant M6x35 screws and then tighten the bolts and washers (For platform length over 120 cm. is necessary to install several railings frames in succession joined by GUC42 clamp with screws M6X35T.E. and nut M6);
- 4) Install the handrails as shown in the figure, placing the round profile on the outer side of the ladder upright and lock it by inserting the "C" U-bolt screw from the inside of the ladder towards

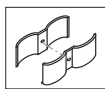

Handrail clamp GUC42 with screws M6X35T.E. and nut M6

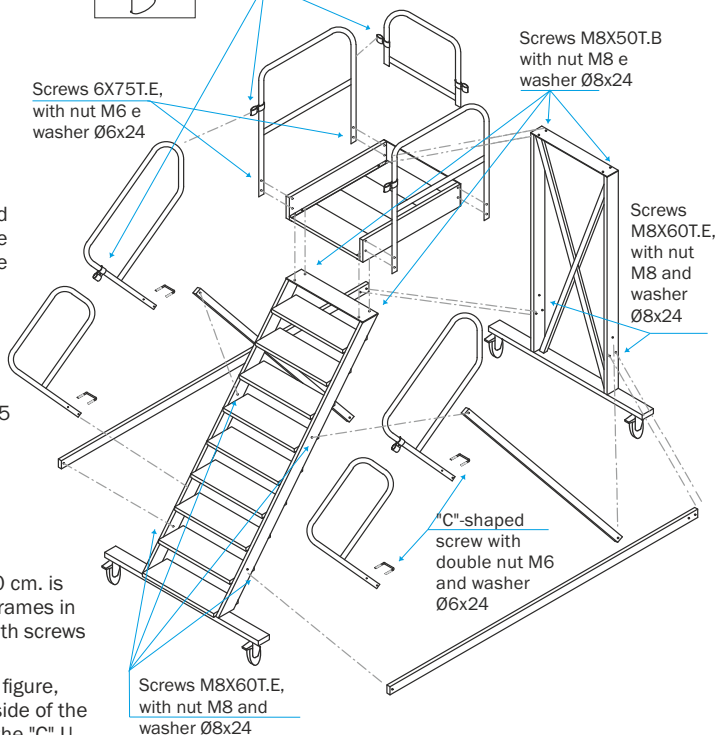

the outside to meet the fixing holes on the round profile, then hook the upper end of the frame to the round profile of the upper handrail frame using the GUC42 hooks and relevant M6x35 screws and tighten the bolts and washers (For sizes over 7 steps it is necessary to install several handrail frames in succession).



*Note: Before climbing the ladder, check that each wheel is properly braked: The brake is activated and deactivated by acting on the front tab with the foot protected by a work shoe.*

*Note: Tighten the screws with manual force alone or similar devices to prevent deformation of the aluminium profiles.*

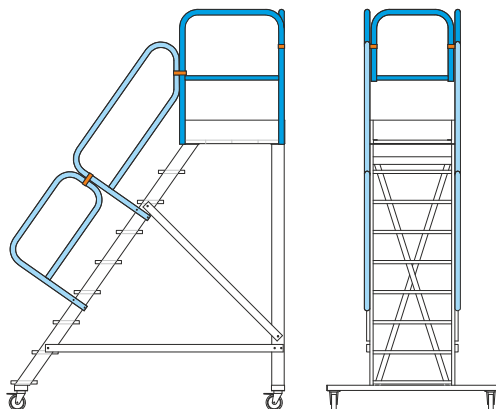

**ATTENTION !** - Before using the ladder, read and understand the general provisions outlined from page 2 to 5



**STANDARDS**

**D.Lgs. 81**



Note: When in use on a platform at a height of more than mt. 2 the ladder must be anchored to avoid the danger of tipping over

Note: Both handrails must always be installed in order to comply with the Italian standard D.Lgs.n°81

**ACCESS TO RAISED FLOORS**

In order to use the ladder also for access to raised floors, with front or side exit, it must be anchored in accordance with Legislative Decree no. 81 of 2008 and equipped with SCS CANCELL opening gate accessory located on the front or side platform side from which you intend to step out.

**Legal obligation according to Italian law Leg-Decree no. 81:**

- The ladder must be anchored to the building or to the raised floor to which access is intended.
- Access to raised floors is only permitted if there is suitable fall protection.
- The maximum distance between the last step of the ladder and the exit floor shall not exceed 20 cm.
- The maximum difference in height between the last step of the ladder and the exit floor must not exceed 25 cm.

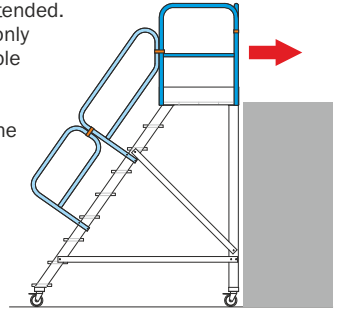

**ARTICLES MADE**

Art. <b>SCA 7760</b> / 03-04-05-06-07 08-09-10-11-12 13-14-15-16-17
Art. <b>SCA 7780</b> / 03-04-05-06-07 08-09-10-11-12 13-14-15-16-17

Art. <b>SCA 7760A</b> / 03-04-05-06-07 08-09-10-11-12-13	Art. <b>SCA 7760C</b> / 03-04-05-06-07 08-09-10-11-12-13	Art. <b>SCA 7760E</b> / 03-04-05-06-07 08-09-10-11-12-13
Art. <b>SCA 7780A</b> / 03-04-05-06-07 08-09-10-11-12-13	Art. <b>SCA 7780C</b> / 03-04-05-06-07 08-09-10-11-12-13	Art. <b>SCA 7780E</b> / 03-04-05-06-07 08-09-10-11-12-13
Art. <b>SCA 7760B</b> / 03-04-05-06-07 08-09-10-11-12-13	Art. <b>SCA 7760D</b> / 03-04-05-06-07 08-09-10-11-12-13	Art. <b>SCA 7760F</b> / 03-04-05-06-07 08-09-10-11-12-13
Art. <b>SCA 7780B</b> / 03-04-05-06-07 08-09-10-11-12-13	Art. <b>SCA 7780D</b> / 03-04-05-06-07 08-09-10-11-12-13	Art. <b>SCA 7780F</b> / 03-04-05-06-07 08-09-10-11-12-13

Art. <b>SCA 7760A</b> / 03-04-05-06-07 08-09-10-11-12-13	Art. <b>SCA 7760C</b> / 03-04-05-06-07 08-09-10-11-12-13	Art. <b>SCA 7760E</b> / 03-04-05-06-07 08-09-10-11-12-13
Art. <b>SCA 7780A</b> / 03-04-05-06-07 08-09-10-11-12-13	Art. <b>SCA 7780C</b> / 03-04-05-06-07 08-09-10-11-12-13	Art. <b>SCA 7780E</b> / 03-04-05-06-07 08-09-10-11-12-13
Art. <b>SCA 7760B</b> / 03-04-05-06-07 08-09-10-11-12-13	Art. <b>SCA 7760D</b> / 03-04-05-06-07 08-09-10-11-12-13	Art. <b>SCA 7760F</b> / 03-04-05-06-07 08-09-10-11-12-13
Art. <b>SCA 7780B</b> / 03-04-05-06-07 08-09-10-11-12-13	Art. <b>SCA 7780D</b> / 03-04-05-06-07 08-09-10-11-12-13	Art. <b>SCA 7780F</b> / 03-04-05-06-07 08-09-10-11-12-13

Art. <b>SCA 7760A</b> / 03-04-05-06-07 08-09-10-11-12-13	Art. <b>SCA 7760C</b> / 03-04-05-06-07 08-09-10-11-12-13	Art. <b>SCA 7760E</b> / 03-04-05-06-07 08-09-10-11-12-13
Art. <b>SCA 7780A</b> / 03-04-05-06-07 08-09-10-11-12-13	Art. <b>SCA 7780C</b> / 03-04-05-06-07 08-09-10-11-12-13	Art. <b>SCA 7780E</b> / 03-04-05-06-07 08-09-10-11-12-13
Art. <b>SCA 7760B</b> / 03-04-05-06-07 08-09-10-11-12-13	Art. <b>SCA 7760D</b> / 03-04-05-06-07 08-09-10-11-12-13	Art. <b>SCA 7760F</b> / 03-04-05-06-07 08-09-10-11-12-13
Art. <b>SCA 7780B</b> / 03-04-05-06-07 08-09-10-11-12-13	Art. <b>SCA 7780D</b> / 03-04-05-06-07 08-09-10-11-12-13	Art. <b>SCA 7780F</b> / 03-04-05-06-07 08-09-10-11-12-13

**LADDER VERSION 7760-7780 WITH ANTI-TIPPING BALLAST ACCESSORY**

**art. SCC ZEN1-60 / art. SCC ZEN1-80**

This anti-tipping ballast accessory can only be applied to the ladder items listed above.

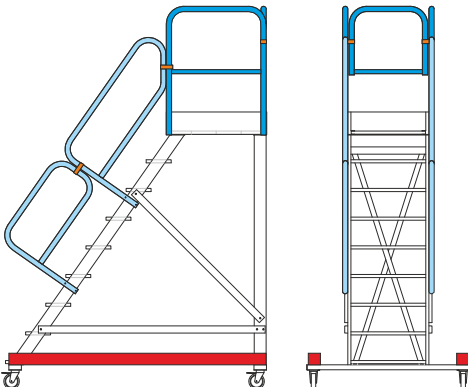

Note: Both handrails must always be installed in order to comply with the European standard EN131

Note: Before climbing up, check that the ballast accommodation box is completely full and well secured to the horizontal spacer bars.

Note: This ladder allows active work because it has been tested to compensate for lateral thrusts up to a maximum of horizontal 30 kg (Before use, check the compatibility in the user manual of the instrument or working machinery used.

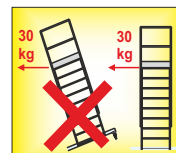

**STANDARDS**

**EN 131/3-7**

**NF P93-352**  
**NF P93-353**



**ATTENTION !** - Before using the ladder, read and understand the general provisions outlined from page 2 to 5



## DOUBLE INDUSTRIAL LADDER WITH BRIDGE WORKING PLATFORM

- 1) Assemble the ladder by joining the landing to the climbing ramps with the M8x50 screws inserted from top to bottom at the holes provided on the fixing plates, then tighten the bolts and washers supplied;
- 2) Install the spacer rods on the outside of the upright profiles with the M8x60 screws inserted from the outside to the inside using the holes provided, then tighten the bolts and washers supplied;
- 3) Install the railings on the outside of the landing upright profiles with the M6x75 screws inserted from the outside to the inside using the holes provided then tighten the bolts and washers supplied (For platform length over 120 cm. is necessary to install several railings frames in succession joined by GUC42 clamp with screws M6x35T.E. and nut M6);
- 4) Install the handrails as shown in the figure, placing the round profile on the outer side of the ladder upright and lock it by inserting the "C" U-bolt screw from the inside of the ladder towards the outside to meet the fixing holes on the round profile, then hook the upper end of the frame to the round profile of the upper handrail frame using the GUC42 hooks and relevant M6x35 screws and tighten the bolts and washers (For sizes over 7 steps it is necessary to install several handrail frames in succession).

Note: All handrails must always be installed in order to comply with the European standard EN131 or Italian standard D.Lgs.n°81

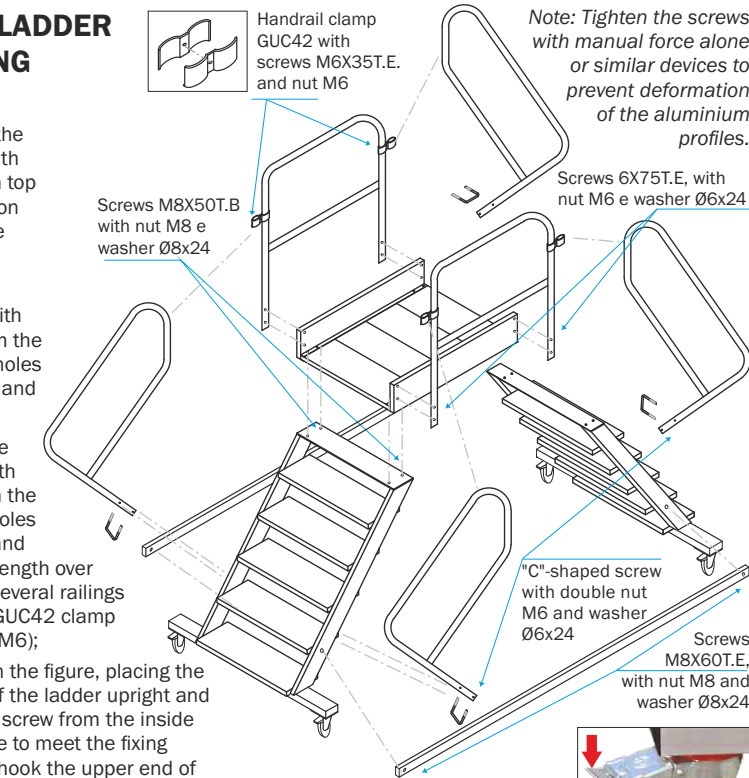

Note: Tighten the screws with manual force alone or similar devices to prevent deformation of the aluminium profiles.

Note: Before climbing the ladder, check that each wheel is properly braked: The brake is activated and deactivated by acting on the front tab with the foot protected by a work shoe.



Note: This ladder allows active work because it has been tested to compensate for lateral thrusts up to a maximum of horizontal 30 kg. (Before use, check the compatibility in the user manual of the work tool used).

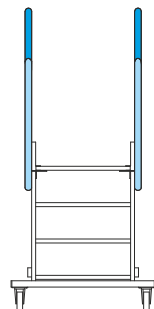
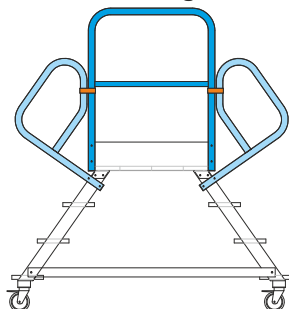

### ARTICLES MADE

Art. <b>SCA 7199</b> / 03-04-05-06-07-08
Art. <b>SCA 7199A</b> / 03-04-05-06-07-08
Art. <b>SCA 7199B</b> / 03-04-05-06-07-08
Art. <b>SCA 7199C</b> / 03-04-05-06-07-08
Art. <b>SCA 7199D</b> / 03-04-05-06-07-08
Art. <b>SCA 7199E</b> / 03-04-05-06-07-08
Art. <b>SCA 7199F</b> / 03-04-05-06-07-08

**STANDARDS**

**EN 131/3-7**

NF P93-352  
NF P93-353

**max. 150kg**

**ATTENTION !** - Before using the ladder, read and understand the general provisions outlined from page 2 to 5



## FIXED INDUSTRIAL DOUBLE-SIDED LADDER WITH BRIDGE PLATFORM

- 1) Assemble the ladder by joining the landing to the climbing ramps with the M8x50 screws inserted from top to bottom at the holes provided on the fixing plates, then tighten the bolts and washers supplied;
- 3) Install the railings on the outside of the landing upright profiles with the M6x75 screws inserted from the outside to the inside using the holes provided then tighten the bolts and washers supplied (For platform length over 120 cm. is necessary to install several railings frames in succession joined by GUC42 clamp with screws M6X35T.E. and nut M6);
- 4) Install the handrails as shown in the figure, placing the round profile on the outer side of the ladder upright and lock it by inserting the "C" U-bolt screw from the inside of the ladder towards the outside to meet the fixing holes on the round profile, then hook the upper end of the frame to the round profile of the upper handrail frame using the GUC42 hooks and relevant M6x35 screws and tighten the bolts and washers (For sizes over 7 steps it is necessary to install several handrail frames in succession);
- 4) Position the ladder in place and check the levelling with the spirit level, then fix the ladder to the ground by means of 10-14 plugs suitable for the type of masonry so that the minimum tightness guaranteed is not less than 300 kg. for each plug.

Note: All handrails must always be installed in order to comply with the European standard EN14122 or italian standard D.Lgs.n°81

Note: The ladder can be used only if it is properly fixed to the ground according to the requirements of Led.Decree no. 81 or EN14122

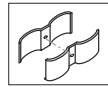
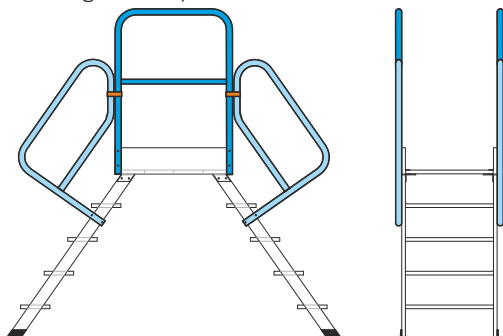

Handrail clamp  
GUC42 with  
screws M6X35T.E.  
and nut M6

Screws M8X50T.B  
with nut M8 e  
washer Ø8x24

Note: Tighten the screws with manual force alone or similar devices to prevent deformation of the aluminium profiles.

Screws 6X75T.E. with nut M6 e washer Ø6x24

"C"-shaped screw with double nut M6 and washer Ø6x24



### ARTICLES MADE

Art. <b>SCA 7260</b> / 03-04-05-06-07-08-09
Art. <b>SCA 7260A</b> / 03-04-05-06-07-08-09
Art. <b>SCA 7260B</b> / 03-04-05-06-07-08-09
Art. <b>SCA 7280C</b> / 03-04-05-06-07-08-09
Art. <b>SCA 7280</b> / 03-04-05-06-07-08-09
Art. <b>SCA 7280A</b> / 03-04-05-06-07-08-09
Art. <b>SCA 7260B</b> / 03-04-05-06-07-08-09
Art. <b>SCA 7280C</b> / 03-04-05-06-07-08-09

**ATTENTION !** - Before using the ladder, read and understand the general provisions outlined from page 2 to 5



## FIXED INDUSTRIAL LADDER FOR INDUSTRIAL ACCESS WITH 60° INCLINATION

- 1) Place the ladder in place and at any step check the horizontal levelling with spirit level;
- 2) Fix the ladder to the top:
  - in case of floor or hooks overexposed to the slab use 10-14 plugs suitable for the type of masonry,
  - In case of vertical wall plate use 12-14 plugs suitable for the type of masonry then check that the minimum tightness guaranteed for each plug is not less than 300 kg;
- 3) Fix the ladder to the ground using 10-14 plugs suitable for the type of masonry, then check that the minimum tightness guaranteed for each plug is not less than 300 kg;
- 4) Install the handrails as shown in the figure starting from the highest handrail downwards, place the round profile on the outer side of the ladder upright and lock it by inserting the "C" U-bolt screw from the inside of the ladder towards the outside to meet the fixing holes on the round profile, then hook the lower end of the frame to the round profile of the lower handrail frame using the GUC42 clamps and relevant M6x35 screws and tighten the bolts and washers (For sizes over 7 steps it is necessary to install several handrail frames in succession);
- 5) Install the railings on the outside of the landing upright profiles with the M6x75 screws inserted from the outside towards the inside using the holes provided, then tighten the bolts and washers supplied (available only for ladder versions equipped with landing with front exit or side exit).

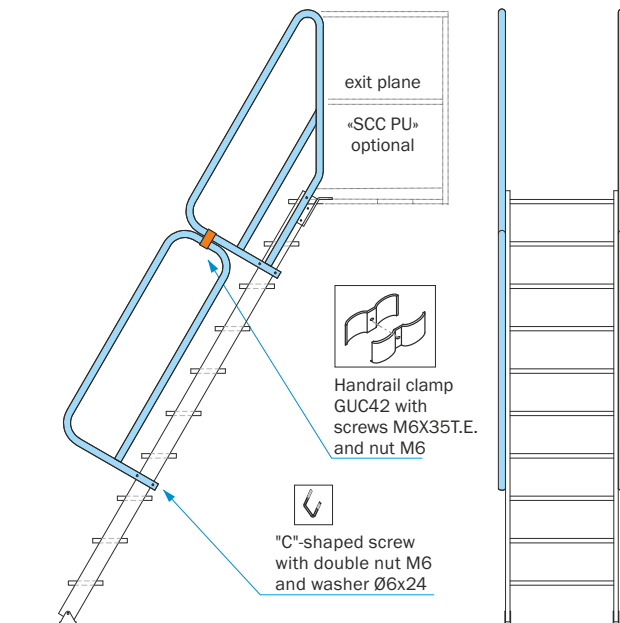

*Note: Tighten the screws with manual force alone or similar devices to prevent deformation of the aluminium profiles.*

*Note: Both handrails must always be installed in order to comply with the European standard EN14122 or Italian standard D.Lgs.n° 81*

*Note: The ladder can be used only if properly fixed to the ground according to the requirements of Leg. Decree no. 81 or EN14122.*

### ARTICLES MADE

Art. **SCA 7366** / 03-04-05-06-07-08-09-10-11-12-13-14-15-16-17-18-19-20-21

Art. **SCA 7368** / 03-04-05-06-07-08-09-10-11-12-13-14-15-16-17-18-19-20-21

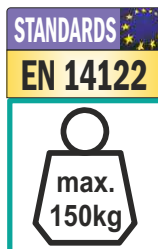

**ATTENTION !** - Before using the ladder, read and understand the general provisions outlined from page 2 to 5



## FIXED INDUSTRIAL LADDER FOR INDUSTRIAL ACCESS WITH 45° INCLINATION

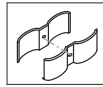

Handrail clamp GUC42 with screws M6X35T.E. and nut M6

Optional SCC PE-QE exit plane

"C"-shaped screw with double nut M6 and washer Ø6x24

Ladder versions 7346 and 7348 up to 14 steps made with sturdy upright profiles mm 95 x 25

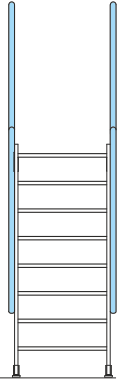

1) Make sure that the slab on which the ladder will rest has an adequate capacity, then place the ladder in place and at any step to check the horizontal levelling with spirit level;

2) Fix the ladder to the top:

- in case of floor or hooks overexposed to the slab use 10-14 plugs suitable for the type of masonry,
- In case of vertical wall plate use 12-14 plugs suitable for the type of masonry then check that the minimum tightness guaranteed for each plug is not less than 300 kg;

3) Fix the ladder to the ground using 10-14 plugs suitable for the type of masonry, then check that the minimum tightness guaranteed for each plug is not less than 300 kg;

4) Install the handrails as shown in the figure, starting from the highest handrail downwards, place the round profile on the outer side of the ladder upright and lock it by inserting the "C" U-bolt screw from the inside of the ladder towards the outside to meet the fixing holes on the round profile, then hook the lower end of the frame to the round profile of the lower handrail frame using the GUC42 clamps and relevant M6x35 screws and tighten the bolts and washers (For sizes over 7 steps it is necessary to install several handrail frames in succession);



Optional SCC PE-QE exit plane

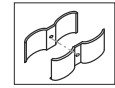

Handrail clamp GUC42 with screws M6X35T.E. and nut M6

"C"-shaped screw with double nut M6 and washer Ø6x24

Ladder versions 7346 and 7348 from 15 steps to 19 steps made with sturdy upright profiles mm 200 x 25

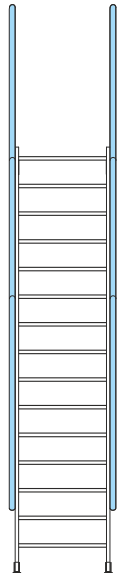

5) Install the railings

on the outside of the landing upright profiles with the M6x75 screws inserted from the outside to the inside using the holes provided then tighten the bolts and washers supplied. (only available for ladder versions with landing with front exit or side exit).

Note: Tighten the screws with manual force alone or similar devices to prevent deformation of the aluminium profiles.

Note: Both handrails must always be installed in order to comply with the European standard EN14122 or Italian standard D.Lgs.n° 81

Note: The ladder can be used only if properly fixed to the ground according to the requirements of Leg. Decree no. 81 or EN14122.

### ARTICLES MADE

Art. **SCA 7346** / 03-04-05-06-07-08-09-10-11-12-13-14-15-16-17-18-19

Art. **SCA 7348** / 03-04-05-06-07-08-09-10-11-12-13-14-15-16-17-18-19



**ATTENTION !** - Before using the ladder, read and understand the general provisions outlined from page 2 to 5



## AERIAL LADDER WITH RIGID STABILIZING BASE AND REST PLATFORM EXTENDABLE WITH ROPE

**WARNING:** for this ladder, assembly and disassembly operations must be carried out by at least 2 persons

- 1) Check that the basic parts have the mounted wheels, in good condition, and that the screw levellers are in perfect working order;
- 2) Assemble the rigid galvanized steel base
  - Join the two mounting plates with the two horizontal tie rods by inserting the screws provided on the outermost holes of the mounting plate,
  - Also attach the diagonal tie rod to the inner holes in the mounting plate;



- 3) Open the ladder in the stand position and by lifting the end of the ladder, hook it to the front mounting plate, at the fixing plates and tighten the steel handwheels firmly, without using tools but only with the force of your hands;
- 4) Hook the rear end of the ladder onto the rear mounting plate, and then install the stabilising brackets from the rear mounting plate to the rear frame of the ladder on the holes provided;



- 5) Lift the third element with the rest platform up to the desired height by pulling the rope; **WARNING:** It is strictly forbidden to raise or lower the rest platform with the operator on the ladder;

- 6) To make the third element descend with the rest platform, pull down the rope to extend the ladder for about another 10 cm to allow the locking latches to be deactivated, then slowly leave the rope to recover the ladder extension;

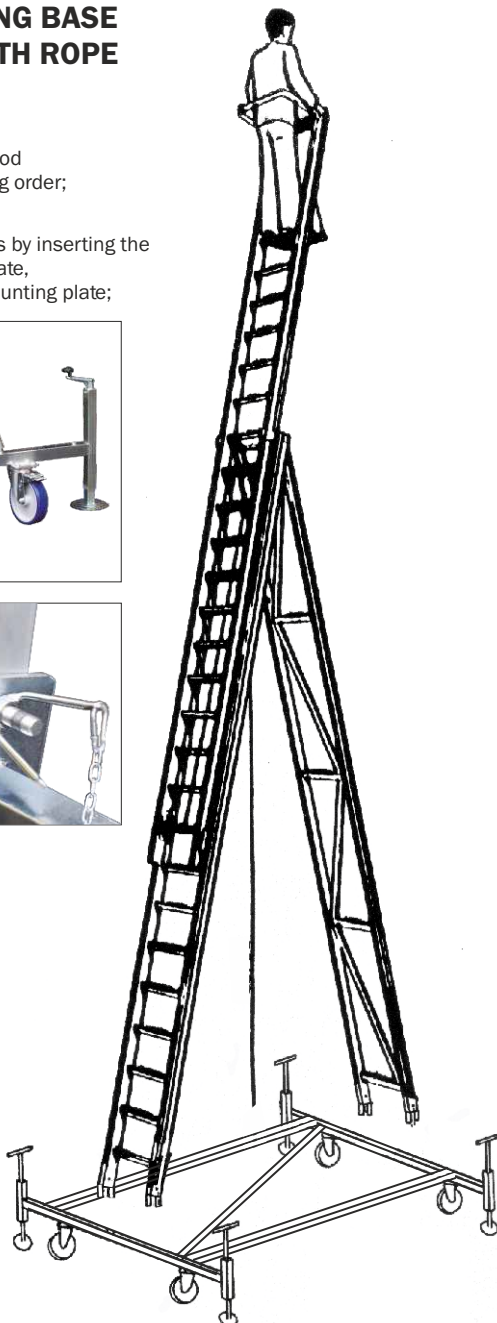

(Blocking is possible at any time by extending the ladder again at the desired step).

Note: Screw stabilisers/levellers only serve to stabilise the ladder and compensate for small differences in height, not to raise the ladder.

Note: When in use on a rest platform at a height higher than mt. 2 the ladder must be anchored to avoid the danger of tipping over.

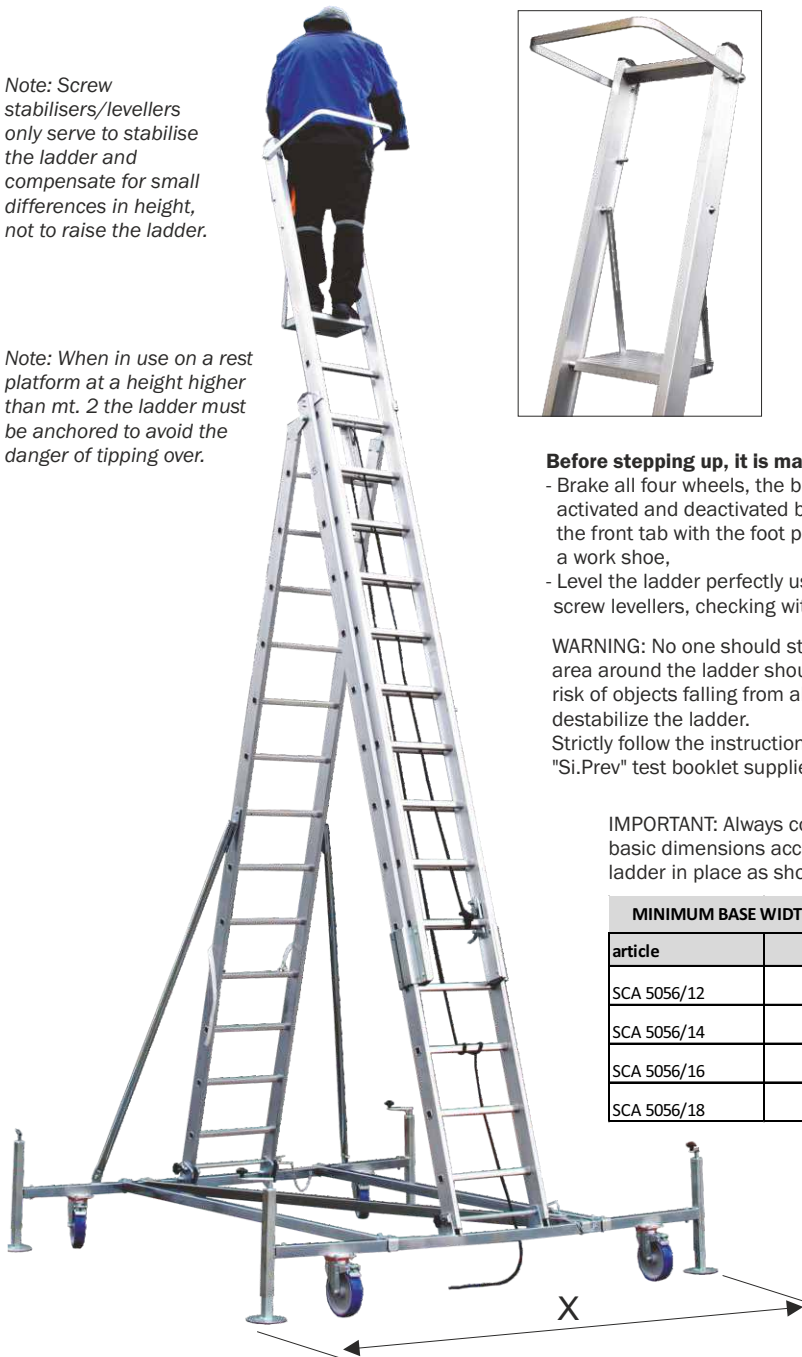

The rest platform opens by itself when the ladder is extended and closes automatically when the 3rd element is retrieved.

The protection bar must be activated manually by the operator once the rest platform is reached.

The operator must always remain inside the rest platform protected by the protection bar and secured with a special anti-fall device anchored to the fixed part (not to the ladder).

**Before stepping up, it is mandatory to:**

- Brake all four wheels, the brake is activated and deactivated by acting on the front tab with the foot protected by a work shoe,
- Level the ladder perfectly using the screw levellers, checking with plumb line or spirit level.



**WARNING:** No one should stand under the ladder: the area around the ladder should be fenced in to avoid the risk of objects falling from above and impacts that could destabilize the ladder.

Strictly follow the instructions given in the specific "Si.Prev" test booklet supplied with the ladder.

**IMPORTANT:** Always comply with the minimum basic dimensions according to the size of the ladder in place as shown in the following table:

**MINIMUM BASE WIDTH understood by the stabilizers**

article	"X" - minimum base width
SCA 5056/12	mt. 2,31
SCA 5056/14	mt. 2,31
SCA 5056/16	mt. 3,11
SCA 5056/18	mt. 3,11



ARTICLES MADE
Art. SCA 5056 / 12-14-16-18

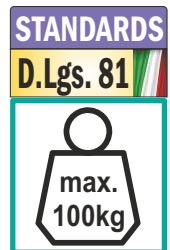

**ATTENTION !** - Before using the ladder, read and understand the general provisions outlined from page 2 to 5



## VERTICAL AERIAL LADDER WITH RIGID STABILIZING BASE AND EXTENDABLE WORKING PLATFORM WITH ROPE

- 1) Check the integrity of all parts of the ladder that are not dented, deformed and/or cracked. Check that the winch-rope-rod system is clean greased and functioning; that the wheels are not worn and that the brakes are working;
- 2) Assemble the rigid galvanized steel base
  - Join the triangular base frames to the mounting plates with the wheels, using the screws provided,
  - Also hook the two small tie rods that join the triangular base frames with the rectangular frame above the wheeled mounting plate in front position;
- 3) Enlarge the stabilizer brackets by loosening the clamps and tightening them again when the maximum extension is reached, then acting on the locking pin stretch the telescopic feet until they touch the ground effectively;
- 4) Insert all the stabilizers/screw levellers in the wheeled mounting plates without exceeding the maximum extension with the words "STOP";

**WARNING:** for this ladder, assembly and disassembly operations must be carried out by at least 2 persons

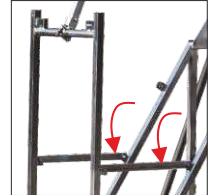

- 5) Lie the ladder on the floor with the platform facing upwards and insert the end of the ladder with the feet between the two triangular base frames from the base side without a rectangular frame until reaching the low perforated plates;
- 6) Then find the matching point of the 2nd rung of the ladder with the holes of the low plates and insert the first threaded fixing bar from the outside of the plate to inside the rung until it comes out on the outside of the opposite plate to lock it with the manual handwheel;

- 7) Raise the ladder by turning it in vertical position until the holes of the high plates match the 7th rung of the ladder, then insert the second threaded fixing bar from the outside of the plate to inside the rung until it comes out on the outside of the opposite plate to lock it with the manual handwheel;

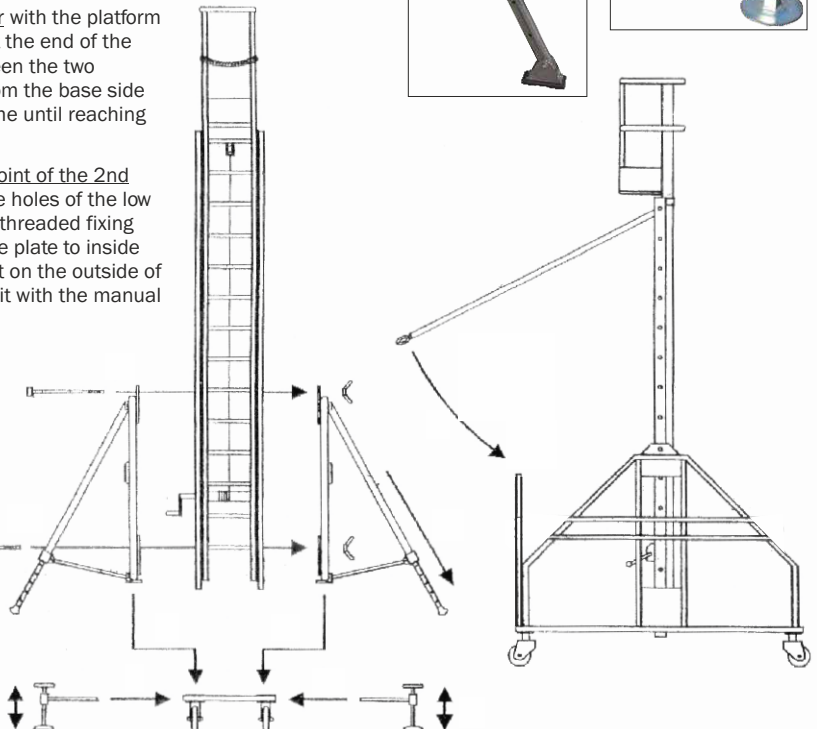

- 8) Anchor the ladder intermediate tie rod with the high tube of the base rectangular frame by tightening the clamp;

**ATTENTION !** - Before using the ladder, read and understand the general provisions outlined from page 2 to 5



9) Extend the second element with the platform by operating the winch crank, when the ladder reaches the desired height make sure that the jumps are triggered and that the ladder rests firmly on them;



10) To lower the second element with the platform it is necessary to make a half turn of the crank in the ascent direction to extend the ladder by about another 10 cm to allow the locking jumps to be deactivated, then turn the winch in the opposite direction to recover the ladder and the platform. (Blocking is possible at any time by extending the ladder to the desired step again).



To put the ladder in the rest position it is sufficient to completely recover the ladder and then unscrew and extract the lower threaded bar and rotate the ladder 180° accompanying it to avoid damage from free fall.

**Before stepping up, it is mandatory to:**

- Brake all four wheels, the brake is activated and deactivated by acting on the front tab with the foot protected by a work shoe,
- Perfectly level the ladder using the screw levellers, checking with plumb line or leveller
- Adjust and aim the stabilizer brackets well on the ground.



**WARNING:**

- It is absolutely forbidden to lift the platform with people and/or objects on the platform.
- It is absolutely forbidden to move the ladder with people and/or objects on board
- No one should stand under the ladder: the area around the ladder should be fenced in to avoid the risk of objects falling from above and impacts that could destabilize the ladder.
- Strictly follow the instructions given in the specific "Si.Prev" test booklet supplied with the ladder

*Note: Screw stabilisers/levellers only serve to stabilise the ladder and compensate for small differences in height, not to raise the ladder.*

Once the operator reaches and accesses the platform he must always manually close both bars of the access gate and thus complete the perimeter guardrail.

The operator must always remain inside the rest platform protected by the railing.

The ascent and descent from the ladder must always be made with a special anti-fall device anchored to the fixed part (not to the ladder).



**STANDARDS**

**D.Lgs. 81**



*Note: When in use on a rest platform at a height higher than mt. 2 the ladder must be anchored to avoid the danger of tipping over.*

**ARTICLES MADE**

Art. **SCA 1913** / 12-14-16



**ATTENTION !** - Before using the ladder, read and understand the general provisions outlined from page 2 to 5



## FIXED INDUSTRIAL LADDER FOR INDUSTRIAL ACCESS WITH VARIABLE INCLINATION FROM 23° TO 78°

- 1) Make sure that the slab on which the ladder will rest has an adequate load-bearing capacity, then position the ladder in place by inclining the ladder until the right height and inclination are obtained
  - the top plates must rest on top of the slab,
  - the lower plates must be flat and parallel to the flooring, thus ensuring the horizontality of all steps;
- 2) Turn the two knobs at the base to ensure that the steps do not change inclination during use;
- 3) Fix the ladder to the top: use 10-14 plugs suitable for the type of masonry of the wall, then check that the minimum tightness guaranteed for each plug is not less than 300 kg;
- 4) Fix the ladder to the ground using 10-14 plugs suitable for the type of masonry, then check that the minimum tightness guaranteed for each plug is not less than 300 kg;
- 5) Install the handrails by inserting the upright tubes into the cast aluminium plates on the outside of the ladder uprights (art. SCC AVP) and tighten the wing nut screw manually.

**WARNING:** Each step is equipped with a tilting mechanism and must be checked before use if:

- There are no damaged, deformed or cracked elements,
- There is no permanent bending of uprights and steps,
- Any cranks, mechanisms, locking devices, if any, are in good working order. Clean or grease if necessary,
- Nuts, screws, rivets are not loose.

*Note:* Tighten the screws with manual force alone or similar devices to prevent deformation of the aluminium profiles.

*Note:* Both handrails must always be installed in order to comply with the European standard EN14122 or Italian standard D.Lgs.n° 81

*Note:* The ladder can be used only if properly fixed to the ground according to the requirements of Leg. Decree no. 81 or EN14122..

### ARTICLES MADE

Art. **SCA AV60** / 05-10-14-15-18

Art. **SCA AV80** / 05-10-14-15-18

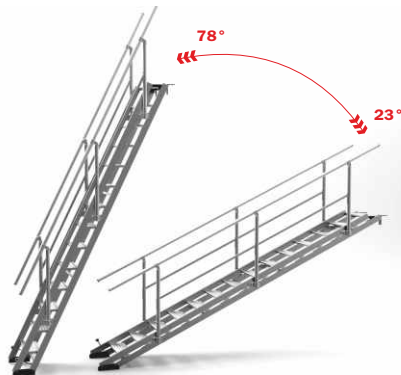
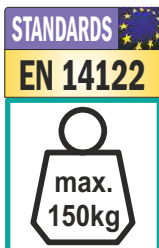

INSTALLATION HEIGHT PER DEGREE OF INCLINATION

ladder code	ladder code	"X" height min 23°	"Y" Max height 78°
SCA AV60/05	SCA AV80/05	mt. 0,63	mt. 1,50
SCA AV60/10	SCA AV80/10	mt. 1,22	mt. 2,93
SCA AV60/14	SCA AV80/14	mt. 1,69	mt. 4,10
SCA AV60/15	SCA AV80/15	mt. 1,90	mt. 4,39
SCA AV60/18	SCA AV80/18	mt. 2,16	mt. 5,27

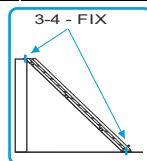
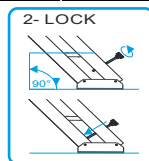
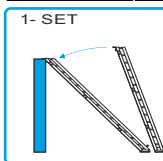

### JOINING MORE LADDER PIECES WITH ARTICULATED OR RIGID FITTING

It requires a design study of implementation and confirmation of feasibility by the Frigerio technical office.

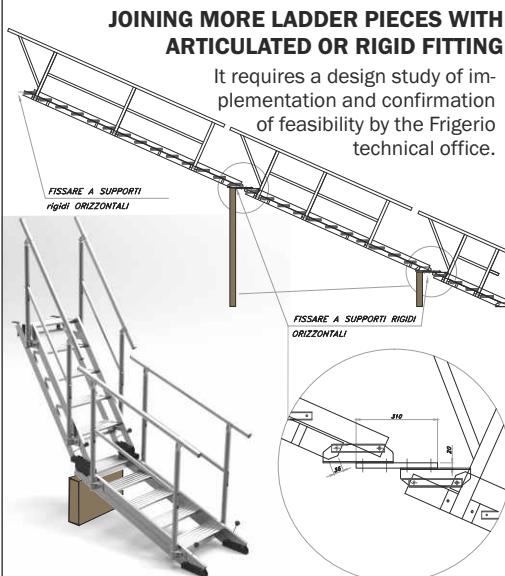

# Reference Standards

From legislative Decree no. 81 dated April 9, 2008

## Art. 111. Employer obligations in using equipment for work above ground

1. The employer, when temporary work above ground cannot be performed in safety conditions and adequate ergonomic conditions from a place suited for this purpose, selects the most appropriate work equipment to guarantee and maintain safe work conditions.. <omissis>
3. The employer ensures that a ladder is only used as an above ground workplace when the use of other work equipment considered safer is not justified due to the limited risk level and short-term use or site features that cannot be modified.. <omissis>
5. The employer, according to the type of work equipment adopted based on the previous points, identifies measures to minimise worker risks, intrinsic to the equipment in question, installing, where necessary, fall protection devices. These devices must have a configuration and resistance to avoid or stop falls from above ground work sites and prevent, where possible, any worker injuries. Group protection devices against falls may only include interruptions in points where there are ladders or rungs.
7. The employer only performs temporary work above ground if weather conditions do not put workers' safety and health in jeopardy.
8. The employer also prohibits workers assigned to above ground work from drinking or administering alcohol or hard liquor.

## Art. 113. Ladders

3. The simple ladders (carried by hand) must be manufactured by proper material for their use, they must be strong enough as a whole and in every single element and they must have proper dimensions for their use... <omissis>  
They must have also:
  - a) non-slip devices on the top and on the bottom of the two uprights.
  - b) Holding hooks or non-slip elements on the top parts, when it is necessary to fix the stability of the ladder
4. For ladders that are equipped with holding devices on the top, even if sliding on rails, the safety devices stated in the letters a) and b) paragraph 3 are not required.<omissis>
5. When the use of the ladder, due to its height or to other reason, causes danger of instability, it must be insured or hold to the foot by another person.
6. The employer shall ensure that the rung ladders are placed in a proper way so that to ensure the stability during their use and following these points: a) the portable rung ladders must be placed on a fixed and strong support. This support must have proper dimensions so that to ensure the horizontal position of the rungs; b) the rung hanging ladders must be fixed in a safety way and, rope ladders a part, in order to avoid any kind of change of position and oscillating movements; c) by using a portable rung ladder, the sliding foot must be prevented by fixing the upper or the bottom part of the uprights, or by using any other non-slip device or any other efficient solution; d) the access rung ladders must be long enough in order to overpass the access level unless there is another device that can grant the safety access; e) the rung ladders composed by different elements must be used so that every element is well fixed; f) the mobile rung ladders must be fixed permanently before to be used.
7. The employers ensures the rung ladders are used so that the operator has in every moment a safety handling support. In particular by carrying a weight on a rung ladder, the operator must always have a safety handle.
8. To use the portable extendable ladder of two or more elements (like the Italian version or similar), in addition to what stated into the paragraph n.3, it is compulsory to follow these points:
  - a) the extended length must not be more than 15mt, except for particular situation and in case the top part of the ladder must be ensured to fixed supports.
  - b) The extended ladders, that are longer than 8, must have the section divider in order to reduce the swaying movement of the ladder.
  - c) No employer must be on the ladder during the lateral movement of the ladder itself
  - d) During the execution of the work, another ground person must pay attention to the ladder.
9. The double ladders must no overpass the 5 mt of length and they must be equipped with chain or some other device that prevent the opening of the ladder over the safety limit.
10. It is allowed the dispensation of manufacturing aspect for the paragraph 3,8 and 8 for the portable ladders that are in compliance with the attachment XX (Cfr. En131).

**Please note: by working on ladder at more than 2 mt of height, it is advisable to be ensured against falls (for example by adopting Italian Presidential Decree Ce harness secured to fixed elements).**

# DECLARATION OF CONFORMITY

We declare that:

All ladders produced by us, including that accompanying this booklet, are manufactured in compliance with the Italian Presidential Decree n. 81 dd. 08/04/2008.

We also declare that to remain in order with previously stated standard, the use instructions labelled on the ladder, that is the warnings described in this booklet, must be strictly adhered to.



FRIGERIO CARPENTERIE S.p.A.  
Il Legale rappresentante

Oriò Al Serio, 01 January 2020

It is hereby declared that the ladder models listed below are tested and certified according to:

- **European standard EN 131, part 1-2-3**,
- or in compliance with **European standard EN 131, part 7** or **NFP093-352/53** when specified,

It is also declared that each step-ladder model listed below is certified according to **European standard EN 14183**

(refer to the identification sticker and serial number on the ladder)

Ladder or Step-ladder code	Description	Conformity and specifications
SCA 7060 / 2-3-4-5	Industrial stool with platform (width 60cm)	EN 14183 (with n°4 SCC PDAI)
SCA 7080 / 2-3-4-5	Industrial stool with platform (width 80cm)	EN 14183 (with n°4 SCC PDAI)
SCA 7100 / 3-4-5-6-7-8	Industrial podium ladder with working platform (width 60cm)	EN 131/7-3 (with n°2 SCC C00/71)
SCA 7199 / 3-4-5-6-7-8-9	Double industrial ladder with bridge platform (width 60cm)	EN 131/7-3 (with n°4 SCC C00/99)
SCA 7199A / 3-4-5-6-7-8-9	Double industrial ladder with bridge platform (width 60cm)	EN 131/7-3 (Compliance on request)
SCA 7199B / 3-4-5-6-7-8-9	Double industrial ladder with bridge platform (width 60cm)	EN 131/7-3 (Compliance on request)
SCA 7199C / 3-4-5-6-7-8-9	Double industrial ladder with bridge platform (width 60cm)	EN 131/7-3 (Compliance on request)
SCA 7199D / 3-4-5-6-7-8-9	Double industrial ladder with bridge platform (width 60cm)	EN 131/7-3 (Compliance on request)
SCA 7199E / 3-4-5-6-7-8-9	Double industrial ladder with bridge platform (width 60cm)	EN 131/7-3 (Compliance on request)
SCA 7199F / 3-4-5-6-7-8-9	Double industrial ladder with bridge platform (width 60cm)	EN 131/7-3 (Compliance on request)
SCA 7260 / 3-4-5-6-7-8-9	Double fixed industrial ladder with bridge platform (width 60cm)	EN 14122 (with n°4 SCC C00/80)
SCA 7260A / 3-4-5-6-7-8-9	Double fixed industrial ladder with bridge platform (width 60cm)	EN 14122 (with n°4 SCC C00/80)
SCA 7260B / 3-4-5-6-7-8-9	Double fixed industrial ladder with bridge platform (width 60cm)	EN 14122 (with n°4 SCC C00/80)
SCA 7260C / 3-4-5-6-7-8-9	Double fixed industrial ladder with bridge platform (width 60cm)	EN 14122 (with n°4 SCC C00/80)
SCA 7280 / 3-4-5-6-7-8-9	Double fixed industrial ladder with bridge platform (width 80cm)	EN 14122 (with n°4 SCC C00/80)
SCA 7280A / 3-4-5-6-7-8-9	Double fixed industrial ladder with bridge platform (width 80cm)	EN 14122 (with n°4 SCC C00/80)
SCA 7280B / 3-4-5-6-7-8-9	Double fixed industrial ladder with bridge platform (width 80cm)	EN 14122 (with n°4 SCC C00/80)
SCA 7280C / 3-4-5-6-7-8-9	Double fixed industrial ladder with bridge platform (width 80cm)	EN 14122 (with n°4 SCC C00/80)
SCA 7366 / 3-4-5-6-7-8-9-10-11-12-13-14-15-16-17-18-19-20-21	Industrial fixed access ladder - 60° inclination (width 60cm)	EN 14122 (with n°2 SCC C00/60)
SCA 7368 / 3-4-5-6-7-8-9-10-11-12-13-14-15-16-17-18-19-20-21	Industrial fixed access ladder - 60° inclination (width 80cm)	EN 14122 (with n°2 SCC C00/60)
SCA 7346 / 3-4-5-6-7-8-9-10-11-12-13-14-15-16-17-18-19	Industrial fixed access ladder - 45° inclination (width 60cm)	EN 14122 (with n°2 SCC C00/40)
SCA 7348 / 3-4-5-6-7-8-9-10-11-12-13-14-15-16-17-18-19	Industrial fixed access ladder - 45° inclination (width 80cm)	EN 14122 (with n°2 SCC C00/40)
SCA 7760 / 3-4-5-6-7-8-9-10-11-12-13-14-15-16-17	Industrial podium ladder with working platform (width 60cm)	EN 131/7-3 (with SCC ZEN60)
SCA 7760A / 3-4-5-6-7-8-9-10-11-12-13	Industrial podium ladder with working platform (width 60cm)	EN 131/7-3 (Compliance on request)
SCA 7760B / 3-4-5-6-7-8-9-10-11-12-13	Industrial podium ladder with working platform (width 60cm)	EN 131/7-3 (Compliance on request)
SCA 7760C / 3-4-5-6-7-8-9-10-11-12-13	Industrial podium ladder with working platform (width 60cm)	EN 131/7-3 (Compliance on request)
SCA 7760D / 3-4-5-6-7-8-9-10-11-12-13	Industrial podium ladder with working platform (width 60cm)	EN 131/7-3 (Compliance on request)
SCA 7760E / 3-4-5-6-7-8-9-10-11-12-13	Industrial podium ladder with working platform (width 60cm)	EN 131/7-3 (Compliance on request)
SCA 7760F / 3-4-5-6-7-8-9-10-11-12-13	Industrial podium ladder with working platform (width 60cm)	EN 131/7-3 (Compliance on request)
SCA 7780 / 3-4-5-6-7-8-9-10-11-12-13-14-15-16-17	Industrial podium ladder with working platform (width 80cm)	EN 131/7-3 (with SCC ZEN80)
SCA 7780A / 3-4-5-6-7-8-9-10-11-12-13	Industrial podium ladder with working platform (width 80cm)	EN 131/7-3 (Compliance on request)
SCA 7780B / 3-4-5-6-7-8-9-10-11-12-13	Industrial podium ladder with working platform (width 80cm)	EN 131/7-3 (Compliance on request)
SCA 7780C / 3-4-5-6-7-8-9-10-11-12-13	Industrial podium ladder with working platform (width 80cm)	EN 131/7-3 (Compliance on request)
SCA 7780D / 3-4-5-6-7-8-9-10-11-12-13	Industrial podium ladder with working platform (width 80cm)	EN 131/7-3 (Compliance on request)
SCA 7780E / 3-4-5-6-7-8-9-10-11-12-13	Industrial podium ladder with working platform (width 80cm)	EN 131/7-3 (Compliance on request)
SCA 7780F / 3-4-5-6-7-8-9-10-11-12-13	Industrial podium ladder with working platform (width 80cm)	EN 131/7-3 (Compliance on request)
SCA AV60 / 5-10-14-18	Fixed industrial access ladder with variable height (width 60cm)	EN 14122 (with n°2 SCC AVC)
SCA AV80 / 5-10-14-18	Fixed industrial access ladder with variable height (width 80cm)	EN 14122 (with n°2 SCC AVC)
SCA 5056 / 12-14-16-18	Three-element aerial ladder with rigid base and resting platform	Si. Prev. Testing
SCA 1913 / 12-14-16	Vertical aerial ladder with rigid base and working platform	Si. Prev. Testing



The «CE» mark cannot be applied to step-ladders, ladders and scaffolds, since they are not covered by the Machinery Directive.

**Edition March 2025**  
All rights reserved