



Frigerio[®]
S.p.A. CARPENTERIE

Instructions and rules of use
of mobile scaffolding on wheels

ITALPONT HD

Mandatory mobile scaffolding
assembly, use,
handling and dismantling
instructions

*This booklet must always accompany
the scaffolding for any submission to
the pertinent bodies*

Settembre 2014

ITALPONT scaffolding instructions for use

Use configuration as per European regulation UNI EN 1004

Nominal capacity on the platform: 200 Kg. uniformly distributed
 Maximum Overall Height: 8,30 metres
 Maximum height off floor: 7,12 metri

NB: European Regulation **UNI-EN 1004** permits non-anchored scaffold use but requires a maximum vertical distance between work platforms or the ground and first platform to be maintained at 4.20 metres and not less than 2.

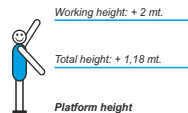

Scaffolding elements

ITALPONT HD <i>Number of section:</i>		ITAL 01	ITAL 01 +MSPC	ITAL 02	ITAL 02 +MSPC	ITAL 03	ITAL 03 +MSPC	ITAL 04	
Working height	mt	3,12	4,12	5,12	6,12	7,12	8,12	9,12	
Overall Height	mt	2,30	3,30	4,30	5,30	6,30	7,30	8,30	
Work floor height	mt	1,12	2,12	3,12	4,12	5,12	6,12	7,12	
Codes	Component List	Weight							
ITAL BLLR	Single levelling base - no wheels	4,5	2	2	2	2	2	2	
ITAL BTEL	Base frame	2,7	1	1	1	1	1	1	
ITAL RUOTA	Wheel Ø 125 mm.	1,5	4	4	4	4	4	4	
ITAL SP	8-rung vertical shoulder	5,6	2	2	4	4	6	8	
ITAL MSP	4-rung half shoulder	3,0	0	2	0	2	0	0	
ITAL TO	Horizontal brace	1,3	2	2	2	2	4	4	
ITAL TD	Diagonal truss	1,5	2	4	4	6	6	8	
ITAL PO	Guard rail	1,5	2	2	2	2	4	4	
ITAL DO	Diagonal Horizontal	1,7	0	0	0	1	1	2	
ITAL PB	Work platform with trapdoor	11,0	1	1	1	1	2	2	
ITAL FERMAP	Toeboard set	6,8	1	1	1	1	2	2	
ITAL STS	Short stabilising brackets	2,6	0	0	4	4	4	0	
ITAL STT	Telescopic stabilising brackets	3,3	0	0	0	0	0	4	
Total weight		Kg	55,5	64,5	79,9	90,6	119,2	130,6	137,5

Designed for flat surfaces

PRATIPONT scaffolding is designed for indoor hobby professional or on perfectly level surfaces. The verticality, verified with a spirit level, must not exceed 1°.

Damaged components should not be used.

Make sure there are all the elements of the scaffold, checking the above table. In case of missing items, replacement with elements not produced by FRIGERIO is prohibited. Make sure that scaffold assembly is not hampered by structures in the air, such as gutters, cantilevered balconies, suspended cables, etc.

Work cannot be performed near power lines less than five metres away.

(Also consider any cable oscillations caused by wind).

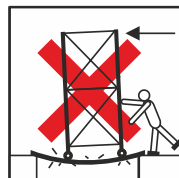

To allow for easier and safe assembly, the scaffold should always be assembled by at least two people, following the procedure specified below

♦ **only people in good mental and physical condition can access raised platforms**

Make sure the surface where the scaffold is assembled is level and stable. Use suitably wide boards to prevent structure collapse.

ITALPONT assembly instructions

The assembly, use and dismantling must always be carried out:

- By at least two operators with a nominal certificate of attendance for a scaffolding assembly, use and dismantling training course
- By operators familiar with the operating modes provided by the manufacturer.
- By operators provided with cords to lift the elements
- By operators equipped with the appropriate PPE: approved helmet, harness with lanyard with energy absorber, positioning belt with cord, safety shoes and gloves.
- Under the control of a responsible supervisor



WARNING

Preliminary

Before starting the assembly of the scaffolding, it is best to check the condition of the scaffold itself, namely the integrity and the perfect functionality of the elements. In particular, check that:

- ◆ Wheels, original and suitable for use, are not damaged, that they turn and that the brakes are functioning;
- ◆ All frames and pipes are straight and not dented;
- ◆ That the platform frame is perfect and that the wood panels are well secure;
- ◆ The anti-release safety latches of the hands of the braces are intact and not blocked;
- ◆ The anti-extension clamps on the vertical shoulders are intact and functioning;
- ◆ If necessary, clean and / or lubricate where required.



Screw levelers

Thanks to the four screw levelers at the base, Italpont can be used on sloping grounds.

You can adjust the screw levelers in three simple steps:

STEP 1: unscrew the lower hand wheel that is a safety device for the accidental unscrewing.

STEP 2: screw the leveler by using the upper handwheel up to reach the adjustment you need.

STEP 3: screw the lower handwheel up to reach the base.

The adjustment of the screw levelers allows the scaffolding to be levelled up to 25 cm and it must be done once that the first section ITAL-01 has been installed.

Check by a level that the verticality is not greater than 1°.

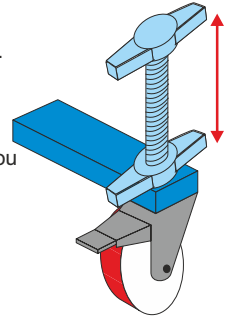

Starting section

- 1) Connect the two base pieces by the stiff frame and by manually tightening the two hammer handwheels on the proper hooks.
- 2) Lubricate the pins on the base and insert the couple of shoulders and make sure the locking clamp clicks.
- 3) Brake the wheels and hook the two diagonal braces crosswise on the first rung as per the drawing (hook from the top to the bottom and make sure that the locking pawl is well done).
- 4) Adjust the high of the telescopic legs to obtain the perfect verticality of the base section. Check it by a spirit level/plumb.
- 5) Mount the 4 stabilizing brackets and adjust them in order to get the best stabilization as described on page n.4. If STT type you need to adjust before extending the telescopic leg using the appropriate locking pin and should only be installed after also mounting the first upper section (as per the drawing).

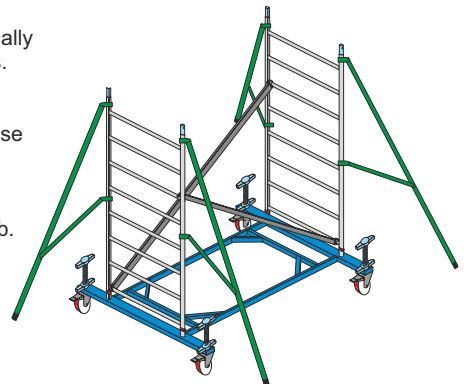

We recommend to install the half section on the end of the scaffold; hook the diagonal braces in continuous and inverse way (as per the drawing) and the platform on the last rung of the lower section.

ASSEMBLY PROCEDURE FOR ITALPONT CONFIGURATIONS WITH TERMINAL PROTECTION SECTION

Upper sections

- 1) Using a suitable positioning device, stop in the middle of a shoulder in the current section and engage the upper shoulder, always making sure the locking clamp clicks.
- 2) Repeat on the opposite side and attach two diagonal braces crosswise, starting from the last rung of the current section [**see I.T.D.**].
- 3) Take a new platform, or reuse the platform already installed in a lower section [**see S.P.F.**] to install it on the last rung of the current section, and then manually remove the anti-lifting safety devices placed under the hooks.
- 4) Climb on the platform through the trapdoor; secure yourself with suitable anti-fall device and hook the protection elements on both sides [**see I.E.P.**].
- 5) Repeat the procedure from point No. 1 through No. 4 until the completion of the terminal section.
- 6) Complete all work platforms, before installing the short toeboards and then the long ones.
- 7) Install the horizontal diagonal brace blocking the terminals on the diametrically opposite vertical shoulder pipes, placing it in the middle of the wider space between two platforms and/or between the ground and the first work platform [**see Fig.1**].

NB To use the ITAL-03+MSPC configuration without anchoring to the fixed part, you must install both the work platforms according to **UNI EN 1004** specifications which requires the distance between work platforms or the ground and the first work platform to be under 4.20 metres (16 braces).

[S.P.F.] - Lifting platforms with cables

- x1) Stand on the platform to be moved, secure yourself with suitable anti-fall device, release the protection elements on both sides and deliver them to the operator on the ground using a rope.
- x2) Securing yourself with a suitable anti-fall device and using a suitable positioning device, pause under the platform to be moved, manually unlock the anti-lifting devices, release it, and hand it over to the operator on the ground using a rope.
- x3) Secure yourself with a suitable anti-fall device and a suitable positioning device; pause under the rung, on which you plan to install the platform, then, using a rope, retrieve the platform from the ground to install it on the rung and manually pull the anti-lifting safety devices.
- x4) Climb on the platform through the trapdoor; secure yourself with suitable anti-fall device and hook the protection elements on both sides [**see I.E.P.**], and install the complete toeboard on the work platform.

[I.E.P.] - The protection elements (horizontal braces and guard rail)

For each work platform, install no. 1 guard rail with reinforced profile on both sides 1.00 mt. from the platform (above the fourth brace over the platform) and no. 1 horizontal brace 0.50 metres from the platform (the second brace over the platform), always hooking the clamp from the top down and placing it between the rung edge and vertical shoulder pipe.

P.S. If when hooking the rail or horizontal brace, you are now in correspondence with a diagonal brace, this can be released and reattached immediately outside the rung edge, to allow then, the operator, to install the protection elements in the correct position, hooking the clamp, between the rung edge and vertical shoulder vertical pipe.

[I.T.D.] - Install the diagonals braces

In a crossed position, between them, within the same section, and maintaining the same direction for each side, between the different sections. Always hook, the brace clamp, with a strong movement from top to bottom, placing it between the rung edge and vertical shoulder pipe.

P.S. The diagonal braces of the upper bays, must be secured to the last brace on the lower bay.

ASSEMBLY PROCEDURE FOR ITALPONT CONFIGURATIONS WITHOUT TERMINAL PROTECTION SECTION

Upper sections

- 1) Install a platform on the 4th rung of the base section, climb on the platform and hook the protection elements on both sides **[see I.E.P.]**.
- 2) Install the pair of upper shoulders, always making sure the lock straps click and attach the two diagonal braces crosswise, starting from the last rung of the current section **[see I.T.D.]**.
- 3) Take a new platform, or reuse the platform already installed in a lower section **[see S.P.F.]** to install it on the 4th rung of the top section and then manually remove the anti-lifting safety devices, placed under the hooks
- 4) Climb on the platform through the trapdoor; secure yourself with suitable anti-fall device and hook the protection elements on both sides **[see I.E.P.]**.
- 5) Repeat from step No. 2 to No. 4, until the completion of the last section.
- 6) Complete all work platforms, before installing the short toeboards and then the long ones
- 7) Install the horizontal diagonal brace blocking the terminals on the diametrically opposite vertical shoulder pipes, placing it in the middle of the wider space between two platforms and/or between the ground and the first work platform **[see Fig.1]**.

NB To use the ITAL-03 o ITAL-04 configuration without anchoring to the fixed part, you must install both the work platforms according to **UNI EN 1004** specifications which requires the distance between work platforms or the ground and the first work platform to be under 4.20 metres (16 braces).

Stabilizing brackets

Correct bracket assembly is essential for the anti-tip safety!

- ✓ When working in contact with a wall, only the brackets in contact can be mounted parallel to the wall.
- ✓ To avoid slippage in the vertical direction, the top bracket clamp must be mounted, if possible, just below the most convenient rung, trying to maintain a 45° angle with respect to the base.
- ✓ The lower clamp is consequently secured by pulling the bracket towards the structure so that it remains well-planted on the ground. Both terminals must be securely tightened.
- ✓ To work on loose soils (loam, gravel, sand) and to avoid sinking, wooden planks must be placed under the wheels and tips of the brackets.
- ✓ Before climbing on scaffolding, during installation, use and after each movement, always check that the brackets are correctly and securely positioned.
- ✓ When moving the scaffolding do not remove the stabiliser brackets, because they can avoid unexpected tipping. These can be easily raised from the ground (a few millimetres) lowering the lower clamp.

The scaffold configurations are designed to operate in indoors and without wind.

In case of wind or drafts, the scaffold must be anchored.

**GENERAL
RULE
in INDOOR
environments**

B £ 1/3 H

The maximum height of the work platform should not be greater than 3 times the minimum of the effective base width, inclusive of base extenders.

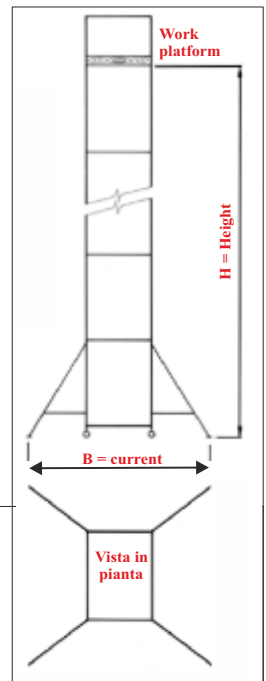

N.B. - In the case in which these conditions cannot be met, the scaffold must be ballasted according to static calculations for each user configuration. Testing available upon request .

Dismantling and storage

Dismantling must be performed by following the assembly instructions in reverse order.

It is strictly forbidden to throw components from above, both for the safety of someone underneath, and for the integrity of the elements. All elements should be stored, avoiding their deterioration or loss or improper use for other functions.

Anchoring Systems

The ITALPONT scaffold, in the use configurations according to the European regulations in this page, is not subject to anchor obligation, but it is still recommended to anchor the scaffolding when possible.

Anchor the scaffolding every 3.60 metres even when, while being assembled, is not used and left unattended.

Anchor the scaffolding to the perimeter uprights and include a max force of kg. 60 to each individual anchor.

Only qualified personnel should perform anchoring. Anchoring by retaining cables (or rigging), which must always be controlled in tension and in the nodes, must be supported by calculation report carried out by a qualified professional.

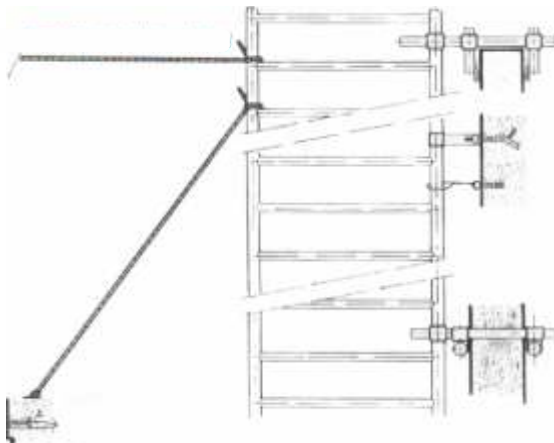

MSPC: Using the half intermediate section

The half intermediate section is composed of: no. 4-rung half shoulders + no. 2 diagonal braces.

The 1 metre terminal section can be used to reach intermediate heights in the different ITALPONT configurations, without exceeding the maximum size of 8,30 m.

E' consigliabile applicare la mezza campata in posizione terminale, agganciando le traverse diagonali in modo continuo e inverso (come da disegno) e il piano di lavoro sull'ultimo gradino della campata inferiore.

ITALPONT use configuration

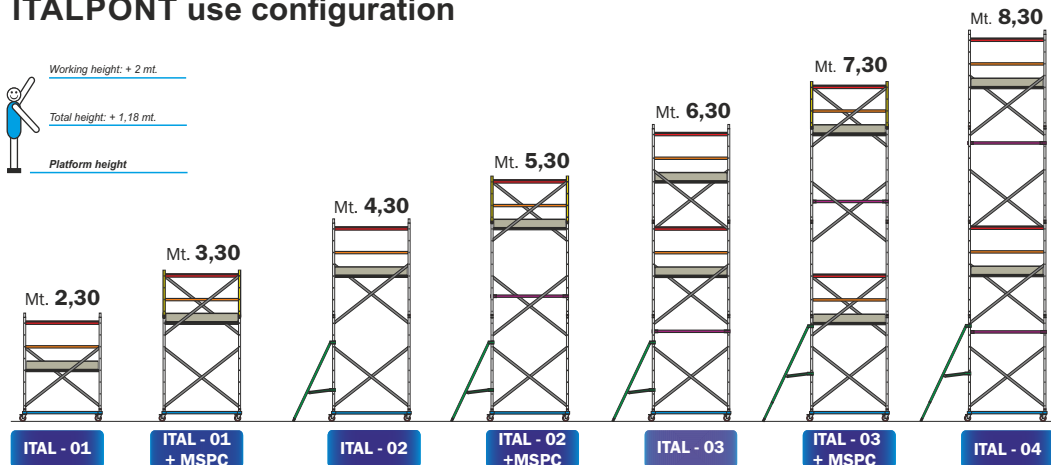

[Figure 1]

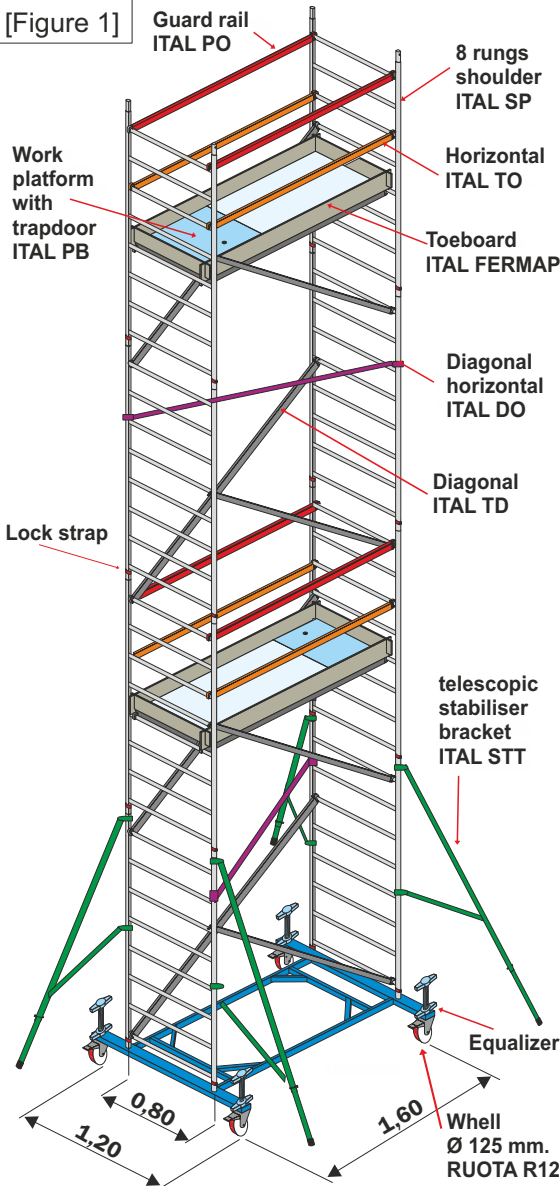

Recommendations for safe assembly at heights over 2 metres:

Anchor the scaffold

Mandatory for all configurations that do not meet European regulations or when the distance between work platforms is over 4 metres. It is best to always anchor the scaffold when possible, adopting one of the anchoring systems indicated on page 6.

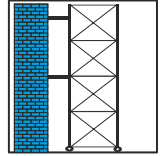

Always stay in the tower

The operator must always climb up and down inside the scaffolding, using the non-slip rungs along the vertical shoulders or a ladders, available upon request.

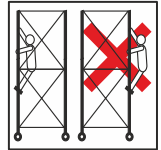

Always work on a work platform

protected by a rail or, secure yourself with suitable anti-fall PPE secured to a fixed part.

Once on the work platform

always make sure the trapdoor is fully closed.

To lift elements

where simple passage from one operator to another is not possible, we recommend lifting them with securely bound cords, this operation should only occur inside the scaffold or extended base (area including the stabiliser brackets). No one should stand under suspended loads.

To simplify

assembly and dismantling procedures, to limit work platform movement, in order to increase operator safety, we recommend purchasing 1 or more additional work platforms.

IMPORTANT:

Brake the wheels

Always very important during assembly, during scaffold use and after each move.

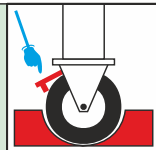

Work platforms

Each work platform is equipped with a trapdoor (mandatory in the tower) and once installed in the final position it must:

- ✓ be secured by manually removing the non-lift devices under the side hooks,
- ✓ equipped with fitted toeboards; be careful that they cannot fall from above, when handling them or due to incorrect assembly.

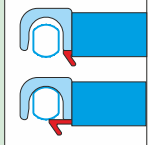

Always assemble the diagonal horizontal

The guarantee torsion rigidity to the structure.

Movement instructions

Movements are only permitted on even and smooth surfaces without any wind.

To move the scaffold, lift the braces not more than 12 millimetres. Movement can only be longitudinally or diagonally.

By unilaterally expanding the base with wall support, movement is only admitted if parallel to the wall.

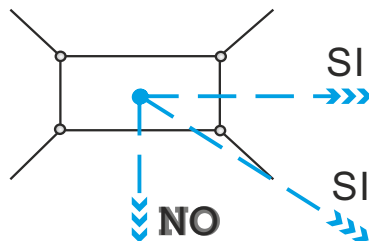

Mobile work towers can only be moved manually.

Materials and/or people should not be on the scaffolding during movement.

Furthermore, people should not be found within a range one and a half times the scaffold height.

Standard walking speed should not be exceeded during movement.

Avoid any destabilising shocks, thus pay attention to obstacles on the ground and in the air. Always keep at least seven metres away from power lines.

The surface on which the scaffolding is moved must be capable of supporting its weight.

Before each use and after each move.

Always check that the mobile work tower is installed following the supplied instructions to guarantee professional assembly and a vertical position.

Before each use, make sure that all safety measures were taken to prevent accidental movement, applying lock brakes and stabilising brackets.

Braking and stabilising the scaffolding is mandatory.

Exceeding a 35 kg horizontal load.

per person, pushing with work tools such as drills, etc., is prohibited.

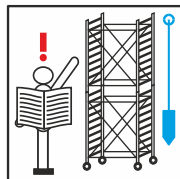
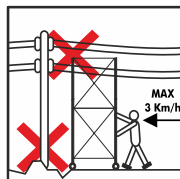

Bridge connections between one mobile work platform and a building or two different scaffolds is prohibited.

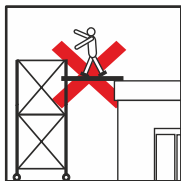

Use and installation of lifting devices is not permitted.

Except for a Frigerio pulley specifically designed for scaffolding with lifting capacity not over 50 kg.

This operation may only occur inside the scaffolding or area between the stabilising brackets

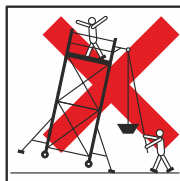

Jumping on scaffolding is prohibited.

Leaning over the lateral section and pushing the scaffold from the top is prohibited.

For scaffolds with various work platforms at different heights, work may only be performed on one platform at a time.

Overloading work platforms exceeding the indicated capacities is prohibited.

Never use ladders or other structures that raise the working height on scaffold platforms. Installing, using and moving scaffolding during strong winds is prohibited.

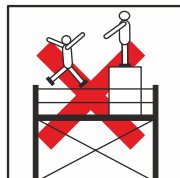

ITALIAN REGULATIONS

Legislative Decree no. 81 dated April 9, 2008

Art. 111 - Employer obligations in using equipment for work above ground

1. The employer, when temporary work above ground cannot be performed in safety conditions and adequate ergonomic conditions from a place suited for this purpose, selects the most appropriate work equipment to guarantee and maintain safe work conditions, according to the following criteria:
 - a) priority to group protection measures over personal protection measures;
 - b) work equipment dimensions suited to the nature of the work to be performed, expected stress and circulation without risks.
2. The employer selects the most suitable type of access system to temporary workplaces above ground in relation to circulation frequency, altitude and duration of work. The adopted access system must permit evacuation in the event of imminent danger. The passage from an access system to platforms, scaffolds, catwalks and vice versa should not infer additional fall risks.
3. The employer ensures that a ladder is only used as an above ground workplace when the use of other work equipment considered safer is not justified due to the limited risk level and short-term use or site features that cannot be modified.
4. The employer ensures that access and positioning systems are used with cords to which the worker is directly supports, only in circumstances in which, following risk assessment, work can be safely performed and the use of other equipment considered safer is not justified due to the short-term use and site features that cannot be modified. The employee ensures the use of a seat equipped with specific accessories according to the risk assessment results and, specifically, work duration and ergonomic restrictions.
5. The employer, according to the type of work equipment adopted based on the previous points, identifies measures to minimise worker risks, intrinsic to the equipment in question, installing, where necessary, fall protection devices. These devices must have a configuration and resistance to avoid or stop falls from above ground work sites and prevent, where possible, any worker injuries. Group protection devices against falls may only include interruptions in points where there are ladders or rungs.
6. For special work, the employer may require the temporary elimination of a group protection device against falls, adopting equivalent and efficient safety measures. Work is performed after adopting these measures. Once this special work is permanently or temporarily completed, the group protection devices against falls must be restored.
7. The employer only performs temporary work above ground if weather conditions do not put workers' safety and health in jeopardy.
8. The employer also prohibits workers assigned to above ground work from drinking or administering alcohol or hard liquor.

Art. 112 - Temporary structure appropriateness

2. Before reusing scaffolding elements of any type, they must be checked to eliminate those no longer deemed suitable as per annex XIX.

Art. 123 - Temporary structure assembly and dismantling

1. Temporary structures must be assembled and dismantled under the direct supervision of a work manager.

Art. 124 - Material storage on scaffolding

1. Storage on service bridges and scaffolding in general is prohibited except for the temporary storage of material and tools necessary for work.
2. The weight of the material and people must always be under the one permitted by the scaffolding's structural resistance; the space occupied by material must permit the movement and manoeuvres necessary for work.

Art. 126 - Guard rails

1. Scaffolding and service bridges, catwalks, walkways, over 2 metres off the ground, must be equipped with a sturdy guard rail in good conditions on all sides facing a void.

Art. 128 - Underbridges

1. Scaffolding and service bridges must have a safety underbridge, built like a bridge, a a distance not over 2.50m.
2. Underbridge construction can be omitted for suspended bridges, for cantilevered bridges and when maintenance and repairs lasting under five days are performed.

Art. 138 - Special regulations

3. Throwing scaffold elements from above is prohibited.

Art. 140 - Mobile scaffolding

- 1) Mobile scaffolding must have ample bases to resist, with ample safety margins, the loads and oscillations they can be subject to during movements or due to wind and to avoid tipping (*Carefully follow the assembly instructions. N.d.P.*)
- 2) The surface in contact with wheels must be level; the scaffold load on the ground must be suitably divided with planks or other equivalent means.
- 3) Scaffold wheels must be securely locked with shims on both sides or equivalent systems.
- 4) Scaffold wheels must be anchored to the constructions at least every two floors; an exception is permitted for mobile scaffolding compliant with annex XXIII (*European regulation compliance. N.d.P.*)
- 5) Mobile scaffold verticality must be checked with a level or pendulum.
- 6) Scaffolds, excluding those used for work on power contact lines, should not be moved when holding workers or loads.

PERSONNEL TRAINING

As for scaffold assembly, dismantling or transformation personnel training, the employer must implement that foreseen by articles 36 and 37 of Legislative Decree 81/08 that clarifies the need to train, educate and inform workers on scaffolding for above ground work.

Circular no. 30/2006 issued by the Ministry of Employment also requires specific training for scaffolding installers.

Riferimenti Normativi:-

- **Uni EN 1004** (2005): "Specification for prefabricated access and working tower (movable scaffold). Materials, components, size, nominal loads and safety requirements".
- **D.M. 27 March 1998** (O.G. no. 102 dated 05/05/1998): "Recognition of compliance to the current norms, of safety means and systems for the building sector, and for the use of tower scaffolds on wheels".
- **EN 1298** (February 1996): "Mobile work towers. Rules and guidelines for the preparation of an instructions manual".

DECLARATION OF CONFORMITY

This is to declare that the ITALPONT mobile scaffolding is constructed in accordance with Legislative Decree No. 81 dated April 18, 2008.

*This is also to declare that the same scaffolding, assembled and used according to the methods described in this manual, meets European Regulation **UNI- EN 1004**.*

On this matter, it is declared that the scaffolding has passed the tests to Legislative Decree 9 April 2008, no. 81 (exception admitted for mobile scaffolding).

The tests were conducted by the Milan Polytechnics Material Test Laboratory, as per test certificate no. 2007 / 2916 issued in Milan on 08/10/2007



POLITECNICO DI MILANO
DIPARTIMENTO DI INGEGNERIA STRUTTURALE
LABORATORIO PROVE MATERIALI
20133 MILANO – P.ZA LEONARDO DA VINCI, 32

Sede di Milano
sezione materiali, Via Celoria, 3 Tel.: 02 2399.4210 Fax: 02-2399.4211

Cod. Fiscale 80057090150
P. IVA 04376620151

Sede di Lecco
Via Promessi Sposi, 29
23900 Lecco
Tel.: 0341-48.8753
Fax: 0341-48.5771

Richiedente: FRIGERIO CARPENTERIE S.P.A. – ORIO AL SERIO

DICHIARAZIONE

Oggetto: ponteggio a torre mobile modello * **ITALPONT** *.

Visti i risultati sperimentali, di cui al nostro certificato n° **2007/2916** emesso in data **08 Ottobre 2007**, e con riferimento alle seguenti prove:

* "Prova di rigidità sulla struttura completa di una torre mobile da lavoro": effettuate in ossequio alle indicazioni della Norma **UNI HD 1004 appendice B**, ed in particolare a:

1. Prova di rigidità con carico orizzontale con stabilizzatori – punto B 3
2. Prova di rigidità con carico orizzontale senza stabilizzatori – punto B 3

si dichiara che le prove di cui ai punti 1 e 2 sopra citati, sono interamente equivalenti alla "Prova di rigidezza sulla struttura completa di una torre" prevista all'**appendice A** della normativa **UNI EN 1004 (2005)**.

Si certifica pertanto che i risultati della sperimentazione sul ponteggio a torre mobile in oggetto sono conformi alle normativa **UNI EN 1004 (2005)**.

Il Responsabile Tecnico

Luigi Sacco



User liability:

The manufacturer cannot be held liable for personal or property damages due to improper scaffolding use or by the full or partial failure to follow the instructions in this booklet, or by failure to conduct periodic checks or maintenance against any damages caused by use or the elements.

We thus recommend you carefully inspect scaffolding parts before use and observe pertinent safety regulations.



Frigerio[®]
S.p.A. CARPENTERIE

Work in safety condition!

