



Frigerio[®]
S.p.A. CARPENTERIE

Instructions and standards for
use of scaffolds on wheels

BALCONY SCAFFOLD

<u>Support structure:</u>	ALP PSA20-25/1 ALP PSA20-25/2 ALP PSA20-25/3
<u>Side cantilever structure:</u>	ALP PSB20-25
<u>Front cantilever structure:</u>	ALP PSC
<u>Rolling scaffold:</u>	ALP PST20-25/1 ALP PST20-25/2 ALP PST20-25/3

**Compulsory warnings
for assembly,
use, movement and dismantling**

IMPORTANT

This booklet must always accompany the rolling scaffold if competent bodies request to see it.

CANTILEVER SCAFFOLD USE - Structures, heights, dimensions and capacities

Support module - Structure "A1" "A2" "A3"

from m. 2.65 to m. 3,15	to m. 2,95 to m. 3,45	to m. 3.25 to m. 3,75 - Height of floor
ALP PSA20 / 1	ALP PSA20 / 2	ALP PSA20 / 3
-	-	- Base dimensions m. 0.74 x 1.97
ALP PSA25 / 1	ALP PSA25 / 2	ALP PSA25 / 3
-	-	- Base dimensions m. 0.74 x 2.55

Side cantilever module - Structure "B"

- ALP PSB20** - Dimensions: m. 0.74 x 1.97 - distributed unif. maximum capacity 120 kg
- ALP PSB25** - Dimensions: m. 0.74 x 2.55 - distributed unif. maximum capacity 120 kg

Front cantilever module - Structure "C"

- ALP PSC** - Dimensions cm. 74 x 74: distributed unif. maximum capacity 120 kg

ROLLING SCAFFOLD USE - Maximum height to treadable surface in compliance with UNI EN 1004

- ALP PST20-25 / 1:** up to m. 2.75 without anchorage in compliance with UNI EN 1004 - capacity 200 kg./m²
- ALP PST20-25 / 2:** up to m. 3.05 without anchorage in compliance with UNI EN 1004 - capacity 200 kg./m²
- ALP PST20-25 / 3:** up to m. 3.35 without anchorage in compliance with UNI EN 1004 - capacity 200 kg./m²

Components and sections

Complete sections

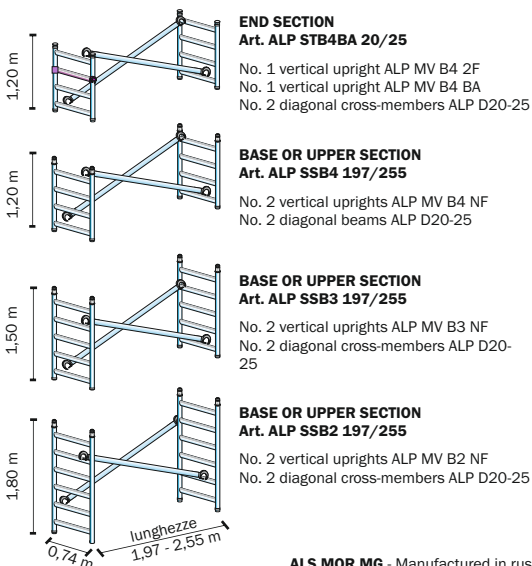

Cantilever support clamps:

Horizontal and diagonal cross-members

Manufactured 100% in aluminium with tubing Ø 50,8 mm. and support hands in dedicated cast aluminium with quick coupling and release device

Levelling feet and legs

Wheels Made in Italy certificated UNI EN 1004 with anti-crushing polyurethane core with red support strip, non-marking, and telescopic legs or counter plates in 100% rust-inhibiting aluminium with anti-removal safety and adjustment handwheel in Counter plate ALP PDB (up to 350 mm.) dedicated cast aluminium

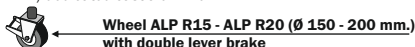

Side and front cantilever sections

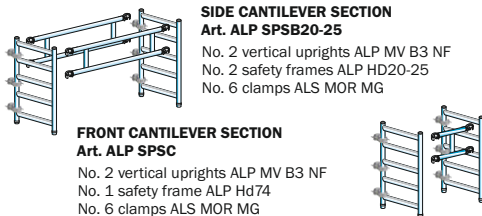

Side and front cantilever work surface

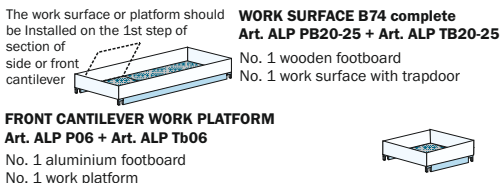

Movement ballast support surface



Ballast elements:

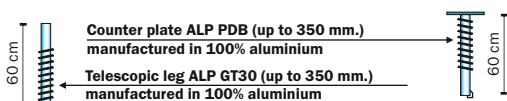
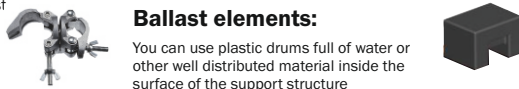

Warnings and Generic Use

N.B. This scaffold can only be assembled, used and dismantled by people familiar with the assembly and use instructions, and with specific training for rolling scaffold assemblers and under the supervision of a supervisor responsible for implementing the provisions of Art. 36 and 37 of Leg. Decree 81/08 [page 16].

Preliminary Operations and Maintenance

It is compulsory to periodically check each year and compile the record on the final pages of the booklet. Before starting assembly of the rolling scaffold, it is a good practice to check its condition, i.e. its intactness and perfect functionality of components. In particular, check that:

- ◆ No damaged or unsuitable components are used,
- ◆ Ensure all elements of the rolling scaffold are in place, comparing the components table; in case of missing elements, it is forbidden to replace with elements that are not original and not manufactured by FRIGERIO,
- ◆ The wheels are original and suitable for use, are not damaged, are free to pivot and the brakes are working,
- ◆ The telescopic legs are not bent and free of dents on the threading.
- ◆ All frames and tubes are intact and not dented; the work surface frame is perfect and the wood panels are well secured,
- ◆ The locking knobs of the locking hands and the non-slip clamps of the uprights are not obstructed by foreign bodies or paint and they are intact and functional.
- ◆ The structure is clean especially at the joints such as hooks and buttons, if necessary lubricate sleeves, and all the joints, brush the telescopic legs to remove paint or dirt deposited,
- ◆ Aluminium is not in contact with muriatic acid, potassium and similar corrosive substances which would damage the product irremediably,
- ◆ The rolling scaffold is stored in a dry and covered place. Do not store in acidic environments or outdoors,
- ◆ The safety harness and fall-arrest systems have been checked regularly as required by applicable regulations.

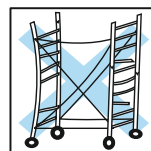
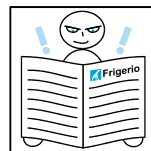

Only people in good mental and physical condition may access scaffolding.

Compulsory WARNINGS

The workplace must be free of hazards, therefore it is necessary to ensure that the work area is safe and suitable by checking:

- The floor or balcony is in good condition, resistant, well-levelled, if necessary use suitably wide planks to prevent the structure from subsiding,
- Assembly of the rolling scaffold is not obstructed by overhead structures such as gutters, balconies, suspended cables,
- There are no electrical lines at a distance of less than seven metres (also consider any wind-induced cable oscillations),
- The wind speed is acceptable and not dangerous and not exceeding 45 km/h (12.5 m/sec).

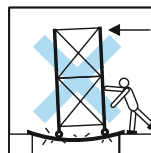

Always stay inside the tower

The operator's ascent and descent must take place inside the rolling scaffold, using the non-slip rungs of the vertical uprights, or any ladders, provided on request. After passing the work surfaces, ensure the trapdoor is closed. Always operate on a work surface, protected with a railing (alternatively, secure yourself with a suitable fall-arrest safety device (P.P.E. according to EC standard).

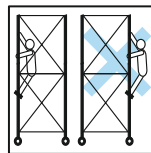

IMPORTANT:

Brake the wheels

It is always important during the assembly, use and after moving the rolling scaffold.

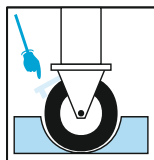

Anchor the rolling scaffold

When possible: use one of the anchorage systems indicated on page 13. Anchorage compulsory for configurations not to European Standard UNI-EN-1004.

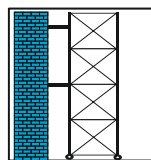

CANTILEVER SCAFFOLD Configuration

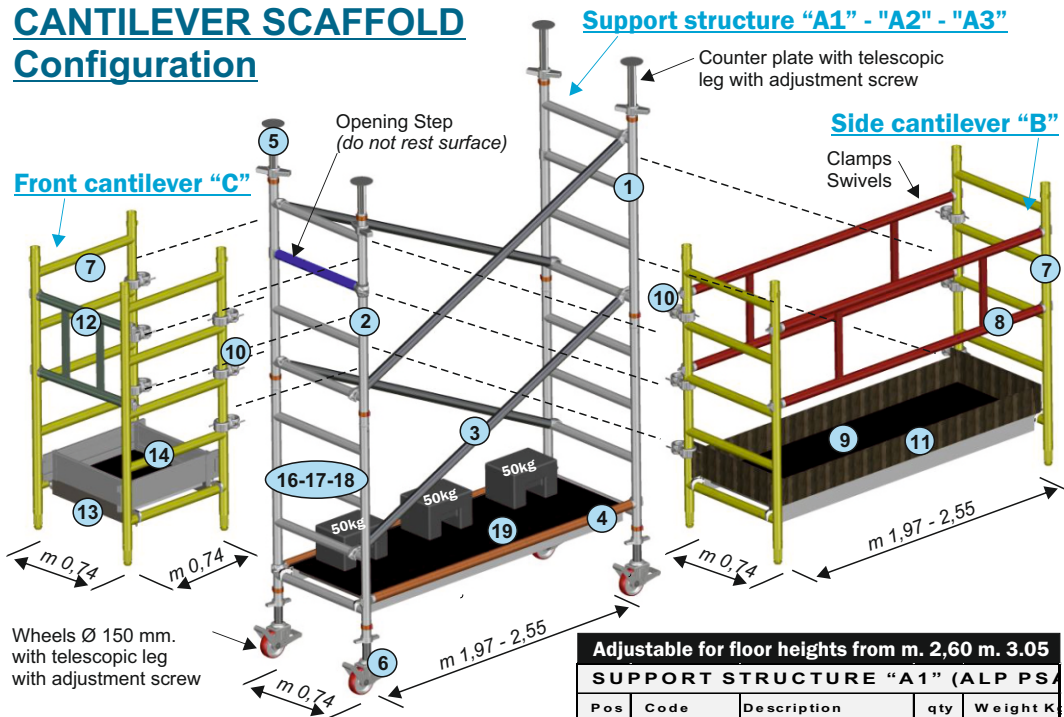

Wheels Ø 150 mm.
with telescopic leg
with adjustment screw

Adjustable for floor heights from m 2,90 3.35

SUPPORT STRUCTURE "A2" (ALP PSA)

Pos	Code	Description	qty	Weight Kg
16	MV B3 NF	Base upright 5 st	2	5.0
1	MV B4 2F	Terminal upright 4 st with double tie	1	3.9
2	MV B4 BA	Terminal upright 4 st with opening step	1	4.8
3	D20-25	Diagonal cross-member	4	1,9 - 2,3
4	H20-25	Horizontal cross-member	4	1,8 - 2,2
5	PDB	Counter plate mm. 150x150x10 levellers	4	2.0
6	QCK RUOT	Wheels 150 mm. with telescopic leg GT30	4	2.8
19	P20-25	Support work surface ballast for movement	1	12 - 17

Adjustable for floor heights from m 3,20 3.65

SUPPORT STRUCTURE "A3"/ALP PSA

Pos	Code	Description	qty	Weight Kg
17	MV B2 NF	Base upright 6 st	2	6.0
1	MV B4 2F	Terminal upright 4 st with double tie	1	3.9
2	MV B4 BA	Montante terminale 4 con giardino apribile	1	4.8
3	D20-25	Diagonal cross-member	4	1,9 - 2,3
4	H20-25	Horizontal cross-member	4	1,8 - 2,2
5	PDB	Counter plate mm. 150x150x10 levellers	4	2.0
6	QCK RUOT	Wheels 125 mm. with telescopic leg GT30	4	3,5
19	P20-25	Support work surface ballast for movement	1	12 - 17

Support structure "A1" - "A2" - "A3"

Counter plate with telescopic leg with adjustment screw

Side cantilever "B"

Clamps Swivels

Adjustable for floor heights from m. 2,60 m. 3.05

SUPPORT STRUCTURE "A1" (ALP PSA)

Pos	Code	Description	qty	Weight Kg
18	MV B4 NF	Base upright 5 st	2	3.9
1	MV B4 2F	Terminal upright 4 st with double tie	1	3.9
2	MV B4 BA	Terminal upright 4 st with opening step	1	4.8
3	D20-25	Diagonal cross-member	4	1,9 - 2,3
4	H20-25	Horizontal cross-member	4	1,8 - 2,2
5	PDB	Counter plate mm. 150x150x10 levellers	4	2.0
6	QCK RUOT	Wheels 125 mm. with telescopic leg GT30	4	3,5
19	P20-25	Support work surface ballast for movement	1	12 - 17

SIDE CANTILEVER "B" (ALP PSB20-25)

Pos	Code	Description	qty	Weight Kg
7	MV B3 NF	Safety upright 5 st	2	5.0
8	HD20-25	Railing	2	4,2 - 5,1
9	PB20-25	Work surface with trapdoor	1	13 - 17
10	MOR MG	Swivel clamps	6	1.0
11	TB20-25	Wooden footboard, waterproof treatment	1	6,5 - 8,0

FRONT CANTILEVER "C" (ALP PSC)

Pos	Code	Description	qty	Weight Kg
7	MV B3 NF	Safety upright 5 st	2	5.0
12	HD74	Railing 74 cm.	1	2.3
10	MOR MG	Swivel clamps	6	1.0
13	P06	Work surface 600 mm.	1	6.0
14	TB06	Aluminium footboard	1	4.1

PRELIMINARY WARNINGS FOR USE OF CANTILEVER SCAFFOLD

- It is always necessary to request intervention of a professionally registered technician who considers the vertical and horizontal forces acting on the support points, evaluating insertion of fixed anchors (if necessary, it is possible to plug into the walls using dedicated holes for \varnothing 11 mm plugs on the counter plates) or load distribution plates in order to ensure safe use.
- It is compulsory to occupy and fence off the entire area below the structure (at road level) To prevent unauthorised personnel from accessing the area, as any falling objects from above could cause serious harm to people and damage property that might pass through or stop in the area below.

Assembly instructions CANTILEVER SCAFFOLD USE

Assembly and dismantling operation must always be carried out:

By at least 2 operators aware of the operating modes provided by the manufacturer, equipped with the specific P.P.E. planned: Certified helmet, fall-arrest harness with energy absorber rope, positioning belt with rope, safety shoes and gloves.

IMPORTANT: Coupling of diagonal cross-members, horizontal cross-members and railing frames

In all scaffolding with ALUPONT system, the diagonal cross-members (**ALP D20-25**) are installed by locking the coupling hand on the step with a decisive movement from top to bottom while all horizontal cross-members (**ALP H20-25**) and railing frames (**ALP HD20-25 e ALP HD74**) installed by locking the hand on the vertical tubes with a decisive movement from inside out.

Assembly of LOAD-BEARING STRUCTURE “A1” - “A2” - “A3”

- 1) Insert the telescopic legs with the wheels in the lower ends of the tubes of the base vertical uprights (ALP MV B2-B3-B4) [Fig.1 on page 13],
- 2) Keeping no. 1 base vertical upright in the vertical position, Couple the no. 1 horizontal cross-member (ALP H20-25) on the upright vertical tube at the height above step 1 and leave the opposite side of the cross-member resting on the ground.
- 3) Position the second base vertical upright, lift the horizontal cross-member from the ground and couple it to the vertical tube of the upright at the height above step 1,
- 4) Similarly, couple no. 1 horizontal cross-member on the opposite side,
- 5) Lock all the wheels (ALP R15-R20) with a decisive movement of the foot on the brake lever,
- 6) Couple no. 2 diagonal cross-sections (ALP D20-25) one on each side in a crossed manner starting from step 1 for the vertical uprights B4 and starting from step 2 for vertical uprights B2 and B3,
- 7) Adjust the height of the telescopic legs (ALP Gt30), until perfect verticality is obtained (equal to or less than 1°) with a level or plumb [Fig.2 on page 13],
- 8) Before climbing on the rolling scaffold, to avoid accidental movements, always check all the wheels have the brake on. Use is optional of suitable wedges [Fig.2 on page 13],
- 9) Position the structure in the work area by checking the position of the side with passage and its height to allow access to a possible cantilever module “C”, then prepare the upper uprights on the ground (ALP MV B4 2F and ALP MV B4 BA) by fully inserting the counter plates with telescopic leg (ALP PDB) into the upper ends of the vertical terminal upright tubes [Fig.1 on page 13],
- 10) Remaining within the structure [see S.P.H. on page 14], climb along the steps of the base vertical upright and connect the terminal upright (ALP MV B4 BA and ALP MV B4 2F) in the desired positions, ensuring the locking elastic tie has clicked into place,
- 11) Repeat the operation on the opposite side [see S.P.H page 14],
- 12) Couple no. 2 diagonal cross-sections (ALP D20-25) one on each side, in a crossed manner starting from step 1 for the terminal vertical uprights and firstly locking the hand on the side opposite that of ascent.

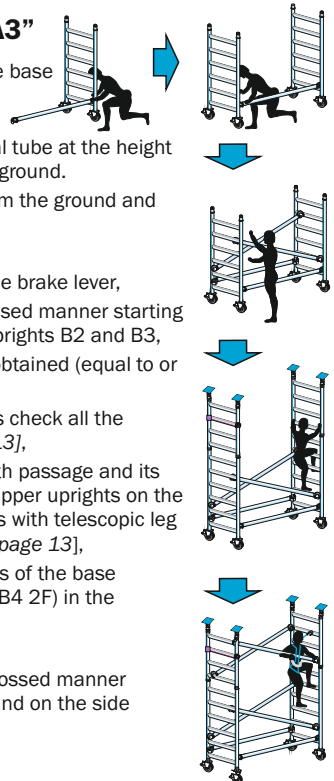

- 13) Adjust the extension of the counter plates (ALP PDB) until they are in contact with the surface of the floor by working on the contrast hand wheel to ensure firm locking by applying manual force to rejection,
- 14) Ensure the scaffolding is firmly set and locked between the floor and the ceiling, then anchor to a fixed part (if necessary it is possible to chip the floor with pre-drilled contrast plates).

Assembly of SIDE CANTILEVER structure “B”

- 1) Prepare the vertical cantilever uprights (ALP MV B3 NF) on the ground by coupling, for each upright no.3, connecting clamps (ALS MOR MG) to the same tube, one in the high position, one in the low position and one in the middle, Remaining inside the structure, attach the vertical cantilever uprights (ALP MV B3 NF) to the external vertical tubes of the support structure, tightening all the clamps manually, so that the cantilever upright (ALP MV B3 NF) is perfectly aligned with the vertical upright of the support structure,
- 2) Repeat the same operation on the opposite side and check the vertical cantilever vertical uprights (ALP MV B3 NF) are parallel to each other [see figure on the side],
- 3) Remaining inside the structure and with the help of a second operator install the work surface (ALP PB20-25) on step 1 of the vertical cantilever uprights (ALP MV B3 NF), then manually remove the anti-lifting safety devices placed under the hooks of the work surface,
- 4) Climb on the cantilever work surface and install the external railing frame (ALP HD20-25) resting the lower hand above step 2 over the work surface and attaching the hands to the external vertical tubes of the cantilever vertical uprights (ALP MV B3 NF), with a decisive movement from the inside out [see figure on the side],
- 5) Also inside the cantilever module. install the railing frame (ALP HD20-25) as described in point (5). Then complete the protection by also installing a full footboard (ALP TB20-25) on the work surface.

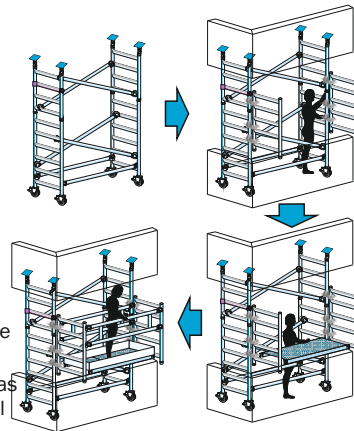

Assembly of FRONT CANTILEVER structure “C”

- 1) Prepare the vertical cantilever uprights (ALP MV B3 NF) on the ground by coupling, for each upright no.3, connecting clamps (ALS MOR MG) to the same tube, one in the high position, one in the low position and one in the middle, Remaining inside the structure, attach the vertical cantilever uprights (ALP MV B3 NF) to the external vertical tubes of the support structure, corresponding to the side equipped with the passage opening step and manually tightening all the clamps, so that the cantilever upright (ALP MV B3 NF) is perpendicular to the vertical upright of the support structure [see figure on the side],
- 2) Repeat the same operation on the opposite side and check the vertical cantilever vertical uprights (ALP MV B3 NF) are parallel to each other.
- 3) Remaining inside the structure install the work surface (ALP P06) on step 1 of the vertical cantilever vertical uprights (ALP MV B3 NF), then manually remove the anti-lifting safety devices placed under the hooks of the work surface [see figure on the side],
- 4) Climb on the work surface and couple the external railing (ALP HD74) and resting the lower hand above step 2 over the work surface and attaching the hands to the external vertical tubes of the cantilever vertical uprights (ALP MV B3 NF), with decisive movement inside out. Then complete the protection by also installing a full footboard (ALP TB06) on the work surface.

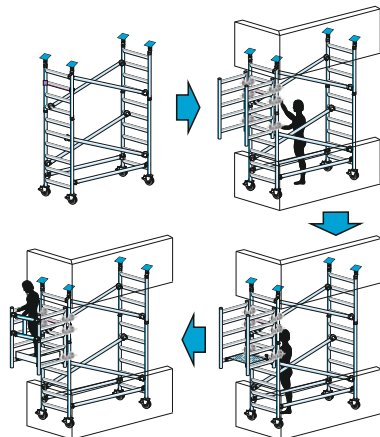

IMPORTANT - During assembly and dismantling of the structures A1 - A2 - A3 - B - C:

working at heights over m. 2 or on cantilever surfaces at heights over m. 2 is always obliged to appropriately secure himself with a suitable fall-arrest safety device (P.P.E. to CE standard) coupled to a fixed structure

Movement instructions CANTILEVER SCAFFOLDING USE

- ◇ Movement is only permitted on flat, smooth surfaces without obstacles and only in the presence of a counter surface (floor) that allows complete and safe support of all no. 4 ceiling counter plates, if the scaffolding has to be tilted to one side.
- ◇ No people or property must be on scaffolding during movement.
- ◇ Normal walking speed must never be exceeded during movement.
- ◇ All destabilising impacts are forbidden, therefore pay attention to obstacles on the ground and in the air.
- ◇ The surface on which the tower is moved must be capable of supporting the weight.

Access to the cantilever modules is not permitted to no. 2 people at the same time

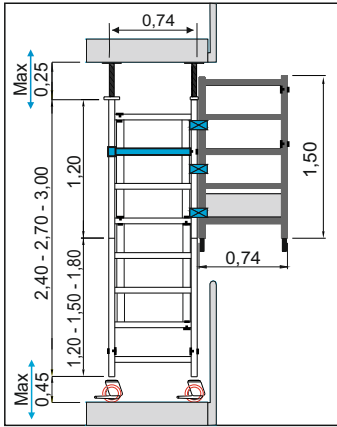

Movement of the supporting structure A1 - A2 - A3 only or the complete structure of both cantilever modules is allowed, with the following procedure:

- 1) Install the ballast support surface (ALP P20-25) on the first step of the support structure A1 - A2 - A3,
- 2) Manually activate the anti-lifting safety devices under the hooks [see page 13],
- 3) Weigh down the work surface with 150 kg. by resting the ballast elements on the ballast support work surface (ALP P20-25) for their optimal distribution on the work surface and they cannot fall during movement,
- 4) Remove all anchorages provided

As ballast elements, it is possible to use water tanks filled up to the top, or other material with a total weight never less than 150 kg. that can be well distributed within the surface of the ballast support surface

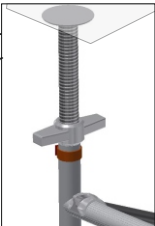
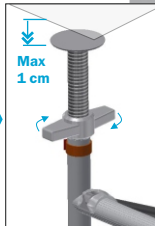
- 4) Lower the counter plates set on the floor by turning the counter hand wheel 1 turn clockwise so that the plates are no more than 1 cm away from the floor surface,
- 

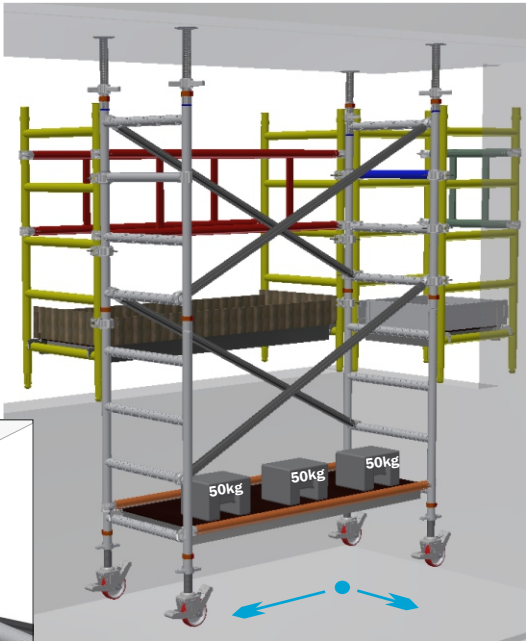
- 5) Unlock all no. 4 wheels and push the structure with manual force only to the desired position.
 - 6) Once you reach the work area, lock the brakes of all wheels, and set all the contrast plates until they are in contact the surface of the floor by turning the counter handwheel for rigid locking applying only manual force until rejection, then reapply the planned anchorages [see page 13].



Before each use and after each movement

It must always be verified that the vertical position is perfect and that the mobile work tower has been assembled regularly and completely according to the instructions given, in order to guarantee a proper execution. Before each use, ensure all safety measures have been taken to prevent accidental movement by applying locking brakes on all wheels and locking the floor counter plates.

ROLLING SCAFFOLD Configuration

The use configurations of the rolling scaffold on these pages comply with the European standard **UNI EN 1004** that allow its non-anchored use.

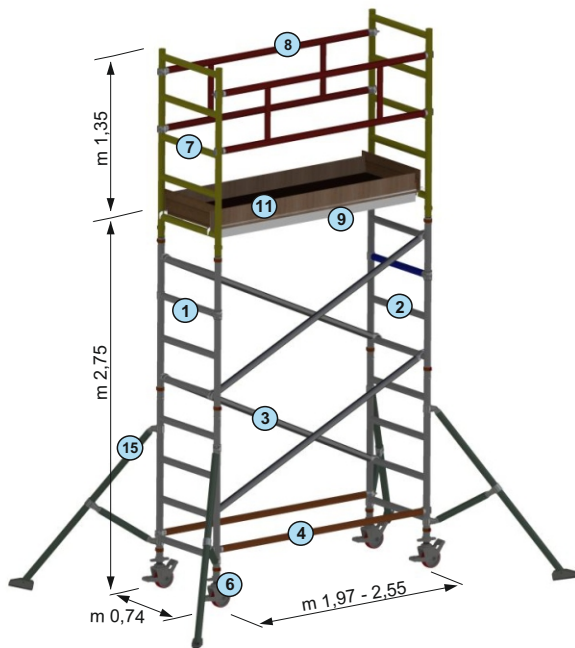

ALP PST20-25 / 1

Lift the elements

To lift the elements, it is recommended that where the height does not allow direct manual passage of the various elements from one operator to another, lift them with a rope. This operation should be carried out exclusively inside the rolling scaffold or extended base (area including stabiliser brackets). Nobody should stand under suspended loads.

Construction of rolling scaffold configurations at higher heights according to UNI EN 1004

By integrating additional components from the ALUPONT B74 range of rolling scaffolds, it is possible to build up the ALUPONT B74 rolling scaffold configurations at heights up to m. 7,92 on the floor in accordance with European standards UNI EN 1004 without obligation of anchoring.

To do so, you must follow the instructions published in the instruction book **ALUPONT B74** in particular you can create all **ALP BS - ALP BHD - ALP BHM** configurations

SUPPORT STRUCTURE "A1" (ALP PSA20-25/1)

Pos	Code	Description	qty	Weight Kg
18	MV B4 NF	Base upright 4 st	2	3.9
1	MV B4 2F	Terminal upright 4 st with double tie	1	3.9
2	MV B4 BA	Terminal upright 4 gr with opening step	1	4.8
3	D20-25	Diagonal cross-member	4	1,9 - 2,3
4	H20-25	Horizontal cross-member	2	1,8 - 2,2
6	QCK RUOT	Wheels Ø 125 mm. with telescopic leg GT30	4	3,5

SIDE CANTILEVER "B" (ALP PSB20-25)

Pos	Code	Description	qty	Weight Kg
7	MV B3 NF	Safety upright 5 st	2	5.0
8	HD20-25	Railing	2	4,2 - 5,1
9	PB20-25	Work surface with trapdoor	1	13 - 17
11	TB20-25	Wooden footboard water-proof treatment	1	6,5 - 8,0

ADDITIONAL COMPONENTS FOR TRANSFORMATION IN ROLLING SCAFFOLD

Pos	Code	Description	qty	Weight kg
15	ST0	Stabiliser braces	4	6.0

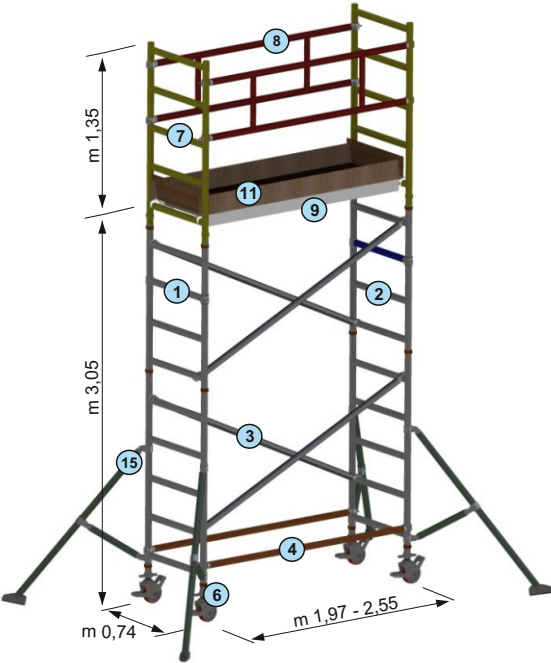

ALP PST20-25 / 2

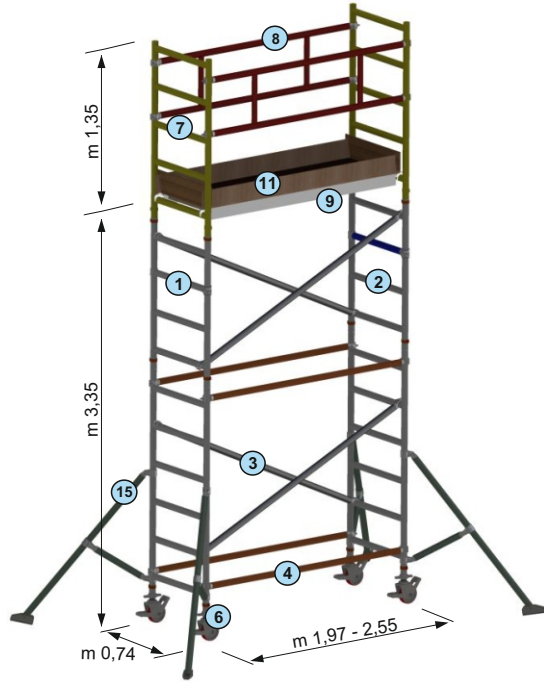

ALP PST20-25 / 3

SUPPORT STRUCTURE "A2" (ALP PSA20-25/2)				
Pos	Code	Description	qty	Weight Kg
16	MV B3 NF	Base upright 5 st	2	5.0
1	MV B4 2F	Terminal upright 4 st with double tie	1	3.9
2	MV B4 BA	Terminal upright 4 gr with opening step	1	4.8
3	D20-25	Diagonal cross-member	4	1,9 - 2,3
4	H20-25	Horizontal cross-member	2	1,8 - 2,2
6	QCK RUOT	Wheels Ø125 mm. with telescopic leg GT30	4	3,5

SUPPORT STRUCTURE "A3" /ALP PSA20-25/3)				
Pos	Code	Description	qty	Weight Kg
17	MV B2 NF	Base upright 6 st	2	6.0
1	MV B4 2F	Terminal upright 4 st with double tie	1	3.9
2	MV B4 BA	Terminal upright 4 gr with opening step	1	4.8
3	D20-25	Diagonal cross-member	4	1,9 - 2,3
4	H20-25	Horizontal cross-member	4	1,8 - 2,2
6	QCK RUOT	Wheels Ø125 mm. with telescopic leg GT30	4	3,5

SIDE CANTILEVER "B" (ALP PSB20-25)				
Pos	Code	Description	qty	Weight Kg
7	MV B3 NF	Safety upright 5 st	2	5.0
8	HD20-25	Railing	2	4,2 - 5,1
9	PB20-25	Work surface with trapdoor	1	13 - 17
11	TB20-25	Wooden footboard water-proof treatment	1	6,5 - 8,0

SIDE CANTILEVER "B" (ALP PSB20-25)				
Pos	Code	Description	qty	Weight Kg
7	MV B3 NF	Safety upright 5 st	2	5.0
8	HD20-25	Railing	2	4,2 - 5,1
9	PB20-25	Work surface with trapdoor	1	13 - 17
11	TB20-25	Wooden footboard water-proof treatment	1	6,5 - 8,0

ADDITIONAL COMPONENTS FOR TRANSFORMATION IN ROLLING SCAFFOLD				
Pos	Code	Description	qty	Weight kg
15	ST0	Stabiliser braces	4	6.0

ADDITIONAL COMPONENTS FOR TRANSFORMATION IN ROLLING SCAFFOLD				
Pos	Code	Description	qty	Weight kg
15	ST0	Stabiliser braces	4	6.0

Assembly instructions ROLLING SCAFFOLD USE

Assembly and dismantling operation must always be carried out:

By at least 2 operators aware of the operating modes provided by the manufacturer, equipped with the specific P.P.E. planned: Certified helmet, fall-arrest harness with energy absorber rope, positioning belt with rope, safety shoes and gloves.

IMPORTANT: Coupling of diagonal cross-members, horizontal cross-members and railing frames

In all scaffolding with ALUPONT system, the diagonal cross-members (**ALP D20-25**) are installed by locking the coupling hand on the step with a decisive movement from top to bottom while all horizontal cross-members (**ALP H20-25**) and railing frames (**ALP HD20-25**) installed by locking the hand on the vertical tubes with a decisive movement from inside out.

Rolling scaffold assembly

- 1) Insert the telescopic legs with the wheels in the lower ends of the tubes of the base vertical uprights
(ALP MV B2-B3-B4) [Fig.1 on page 13],
- 2) Maintaining a base upright in the vertical position, couple the no. 1 horizontal cross-member (ALP H20-25) on the upright vertical tube at the height above step 1 and leave the opposite side of the cross-member resting on the ground.
- 3) Position the second base vertical upright, lift the horizontal cross-member from the ground and couple it to the vertical tube of the upright at the height above step 1,
- 4) Similarly, couple another horizontal cross-member on the opposite side,
- 5) Lock all the wheels (ALP R15-R20) with a decisive movement of the foot on the brake lever,
- 6) Couple no. 2 diagonal cross-sections (ALP D20-25) one on each side in a crossed manner starting from step 1 for the vertical uprights B4 and starting from step 2 for vertical uprights B2 and B3,
- 7) Adjust the height of the telescopic legs (ALP Gt30), to obtain perfect verticality to check with a level/plumb. (Verticality must not be over 1°) [Fig.2 on page 13],
- 8) Before climbing on the rolling scaffold, to avoid accidental movements, always check all the wheels have the brake on. Use is optional of suitable wedges [Fig.2 on page 13],
- 9) Remaining within the structure [see S.P.H. on page 14], climb along the steps of the vertical upright and connect the terminal vertical upright (ALP MV B4 BA), ensuring the locking elastic tie has clicked into place, Repeat the operation on the opposite side (for ALP MV B4 2F),
- 10) Couple no. 2 diagonal cross-sections (ALP D20-25) one on each side [see. page 14], in a crossed manner starting from step 1 for the terminal vertical uprights and firstly locking the hand on the side opposite that of ascent [see S.P.H. on page 14],
- 11) Before proceeding, install the stabiliser brackets [See page 12],
- 12) Remaining within the structure [see S.P.H. on page 14], climb along the steps of the vertical upright and connect the safety upright (ALP MV B3 NF), with the pins turned downwards and ensuring the locking tie has clicked into place, Repeat the operation on the opposite side.
- 13) Tie two ropes safely on both ends of the work platform.
- 14) The operator at a height must be positioned on the last upper section with his head at the height of the last step,
- 15) While the operator at a height lifts the surface by pulling one rope, the other operator climbs vertically on the opposite side of the tower to guide the platform up with the other rope,
- 16) Once at the top, both operators install the platform on the last step of the last upper section. Block the wind protection under the surface.

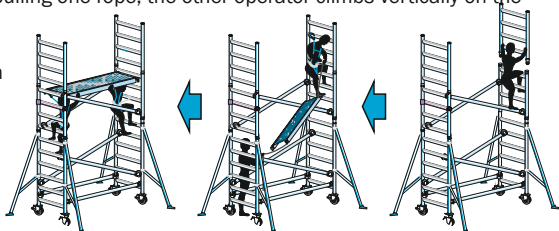
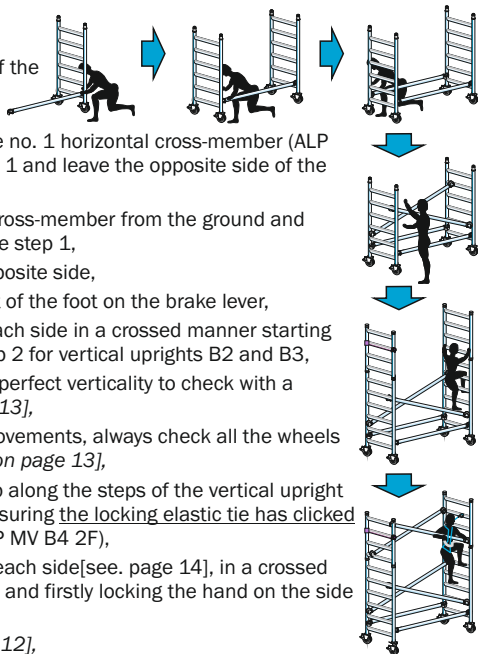

- 17) Using the steps, climb internally through the trapdoor to mid-torso and sit on the surface keeping your legs inside the trapdoor and couple the two safety frames (ALP HD20-25) [see S.S.A. Page 14],
- 18) Complete the work surface by installing the complete footboard (ALP TB20-25).



IMPORTANT - During assembly and dismantling of the cantilever modules:

The operator working at heights over m. 2 is always obliged to appropriately secure himself with a suitable fall-arrest safety device (P.P.E. to CE standard)

Movement instructions - ROLLING SCAFFOLD USE

Movements are only permitted on perfectly flat, smooth,

compact surfaces free of obstacles, as well as in the absence of wind. To move the rolling scaffold, lift the brackets, but no more than 12 millimetres.

Movements can only take place in the longitudinal or diagonal direction on plan. If working against a wall, then with unilateral widening of the base, movement is only allowed if performed parallel to the wall.

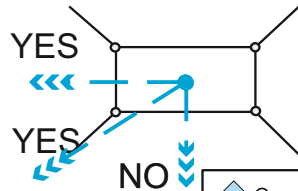

The mobile towers can only be moved manually.

During movement, no people or property must be on scaffolding. Furthermore, nobody must be in the range equal to one and a half times the height of the rolling scaffold.

Normal walking speed must not be exceeded during movement.

All destabilising impacts are forbidden, therefore pay attention to obstacles on the ground and in the air. Always keep a distance of at least seven metres from high voltage electricity cables and at least five metres from low voltage electricity cables. The surface on which the tower is moved must be capable of supporting the weight.

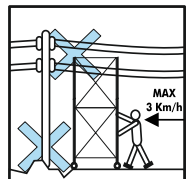
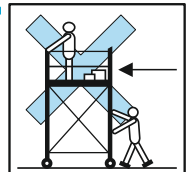

Before each use (and after each movement)

It must always be verified that the vertical position is perfect and that the mobile work tower has been assembled regularly and completely according to the instructions given, in order to guarantee a proper execution.

Before each use, ensure all safety measures have been taken to prevent accidental movement by applying locking brakes on all wheels and the no. 4 stabiliser brackets.

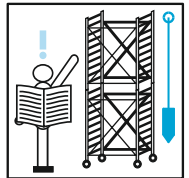

Bridge connections are not permitted between a mobile tower and a building, and between two different rolling scaffolds.

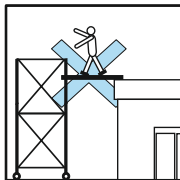

Use is not permitted of lifting devices

(except pulley ALP CARRU with rotating jib ALP BANGI)
It is also forbidden to exceed 35 kg. of horizontal load per person, pushing with work tools, such as drills, etc.

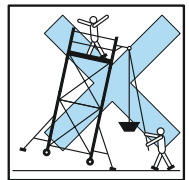

It is forbidden to jump on scaffolding.

It is forbidden to lean with the body beyond the side section and push the rolling scaffold from above.

For rolling scaffolds with different work platforms, work on one platform only at a time.

It is forbidden to overload the work surfaces exceeding the indicated capacities.

Never use ladders or superstructures on scaffolding that raise the working height. It is forbidden to assemble, use and move rolling platforms in strong wind.

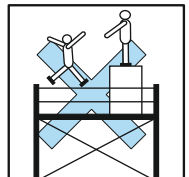

Base extenders

Correct assembly of brackets is essential for safety against overturning.

- ✓ Base extenders must be assembled according to the height and environmental conditions, as indicated in the table on this page.
- ✓ If working in contact with a wall, the only contact brackets may be mounted parallel to the wall.
- ✓ If the ground is soil, it must not be too soft or wet and to avoid sinkage, it is necessary to use wooden boards placed both under the wheels and under the tips of the brackets.
- ✓ Always check the brackets are correctly and firmly positioned before climbing onto the rolling scaffold, during assembly, use and after each movement.
- ✓ Do not remove the stabiliser brackets when moving the rolling scaffold, as they can prevent unexpected tip-over. The brackets can be easily raised from the ground (a few millimetres) by lowering the lower clamp.

Assemble the base extenders

The **ST0** and **ST1** extenders are fixed on the base vertical uprights while the **ST3** extenders also work on the upper uprights (*therefore before installing the latter, you must complete the upper section as well*):

- 1) Adjust the extension of the telescopic leg and insert the locking pin (*for telescopic extenders*).
- 2) To avoid vertical slipping, the upper clamp of the bracket should be assembled, if possible just below the most comfortable step, trying to maintain a 45° angle from the ground.
- 3) The lower clamp is fixed accordingly by accompanying the lower arm along the vertical upright to pull the bracket towards the structure so that the oscillating foot is firmly set on the ground.
- 4) Orient the bracket 45° according to the base so that it covers as much surface as possible.
- 5) Tighten both clamps by manual force only.

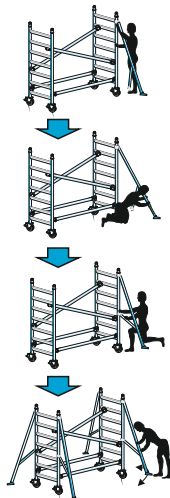

[Fig. 4]:

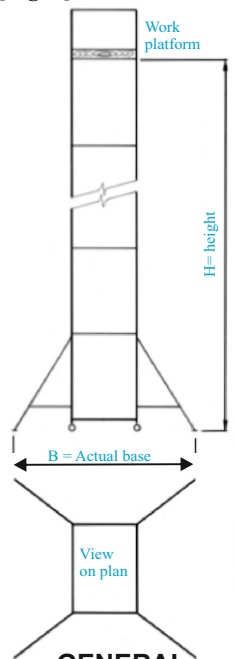

GENERAL RULE in INDOOR environments

$$B \leq 1/3 H$$

The maximum height of the work surface must not be more than 3 times the minimum width of the effective base, including the base extenders.

Application of stabiliser brackets in indoor or outdoor environments

The correct choice of model of stabiliser brackets is based on the height to be reached and the presence or absence of destabilising air flows, so the extender model can change, depending on whether you operate in outdoor or indoor environments.

The following table describes, for each configuration that can be used without anchorage in accordance with **UNI EN 1004**, the minimum width of the base area to be covered by the stabiliser brackets, depending on the surface height you want to reach.

N.B. - If these conditions cannot be met, the rolling scaffold must be weighed down according to a static calculation specific for each use configuration.

ROLLING SCAFFOLD model	ENVIRONMENT indoor - outdoor	HEIGHT on floor MAX m.	BRACKET recommended type	BASE WIDTH minimum to reach m. mt. A x mt. B	WORK PLATFORM minimum no.
PST20 - 1	Indoor and Outdoor	2,75	ST0	3,51 x 2,28	1
PST25 - 1	Indoor and Outdoor	2,75	ST0	4,09 x 2,28	1
PST20 - 2	Indoor and Outdoor	3,05	ST0	3,51 x 2,28	1
PST25 - 2	Indoor and Outdoor	3,05	ST0	4,09 x 2,28	1
PST20 - 3	Indoor and Outdoor	3,35	ST0	3,51 x 2,28	1
PST25 - 3	Indoor and Outdoor	3,35	ST0	4,09 x 2,28	1

Check the base area meets the minimum measures for A and B indicated in the table, in the item "BASE WIDTH"

HEIGHT : height on surface.
OUTDOOR : presence of breeze (maximum 12 m/s).
INDOOR : closed premises and protected from draughts.

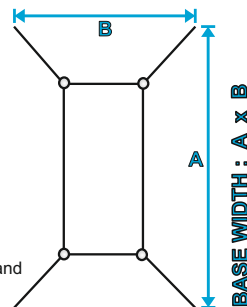

Work surfaces, service surfaces and footboards

- Work platform or work surface means the floor covering the entire internal surface of the scaffold and must be complete with standard footboards and railings.
- Platform or service surface means any intermediate passage surface or semi-surface that cannot be used as a work surface.
- It is compulsory to install complete stop-links on all work platforms and intermediate service platforms.
- Footboards are fitted: firstly, place the long boards with the hollows facing up and then the short ones (see figure on the side).
- European standards UNI EN 1004 stipulates that there is a maximum vertical distance of m. 4.20 between the work surfaces and a minimum vertical distance of m. 2.10.
- For the Alupont rolling scaffold, the distance between one level and the next must be from a minimum of 7 to a maximum of 14 steps.
- Once the work surface is in position, always manually activate the anti-lifting safety devices under the hooks (see figure on the side).

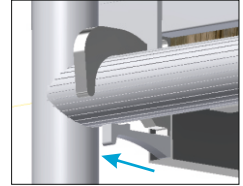
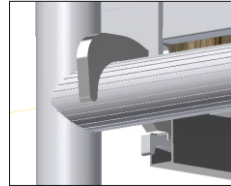
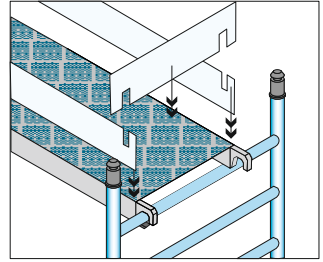

Anchorage and anti-overturning systems

Where possible, mobile work towers used outside buildings must be securely fastened to the building or another fixed structure.

If working on façades, the rolling scaffold should be anchored in height every m. 4 and for both vertical tubes on the side facing the wall.

In the event of wind force 6 (12 m/s), of a storm coming and at the end of the work shifts, the scaffolding must be pushed into a premises protected from the wind, dismantled or anchored to prevent it from overturning.

Anchor the rolling scaffold to the perimeter uprights and with a maximum force of kg. 60 on each anchorage. The anchoring operation must only be carried out by competent personnel.

Anchor by means of retention cables (or tie-down), whose tension and knots must be checked, must be supported by a calculation report by a qualified professional.

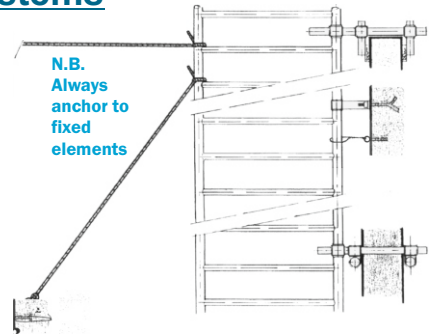

[Fig. 1]: Composition of telescopic leg.

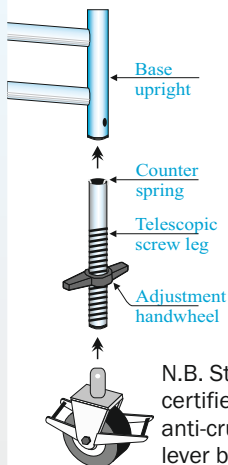

The telescopic leg is only used to level and must not be used to lift the rolling scaffold!

N.B. Standard wheel Ø 150 mm. certified EN 1004 with nylon, anti-crushing core with double lever brake

[Fig. 2]: Regolazione della gamba telescopica.

Always check, before each use, that the rolling scaffold is perfectly vertical!

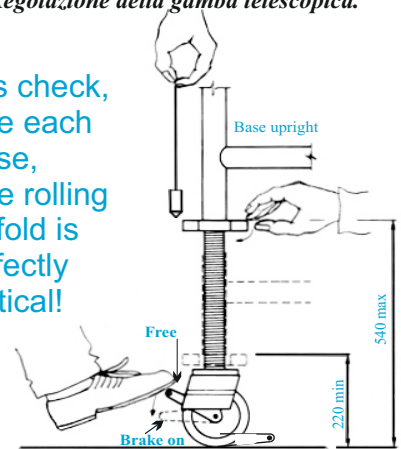

Useful adjustment height: 32cm.

Movement of elements after completing structure assembly

If necessary, you can position the work surfaces at intermediate heights not planned by the standard configurations indicated, provided:

- The work surface is complete with side railings (ALP HD20-25) and complete footboards.
- It is possible to move the diagonal cross-members (ALP D20-25) or horizontal cross-members if necessary (ALP H20-25) within the same section, provided no further cross-sections are simultaneously detached
- To comply with European legislation, there must be no more distance than m between a work surface and the next. 4.20 (no. 14 small cross-sections).

**IT IS STRICTLY FORBIDDEN TO DETACH MULTIPLE
DIAGONALS FROM THE SAME SECTION SIMULTANEOUSLY**

DISMANTLING PROCEDURE - All versions

For each ALUPONT version, dismantling must be carried out in reverse order to the assembly instructions of the same version. Any additional dismantling procedures are described in the reference configuration assembly procedure.

It is strictly forbidden to throw components from above, both for the safety of the people below, and to maintain the integrity of the elements that must be kept, avoiding their deterioration, or loss, or misuse for other functions.

"ASSEMBLY AND DISMANTLING OF THE PROTECTION SECTION (P.S.A.)"

Procedure describing the correct movements required to install the safety elements on a work platform without leaving a safety condition:

- 1) Securing the harness rope, climb internally through the passage trapdoor (using the vertical element steps or the service ladder) to mid-torso and sit on the surface, however keep your legs inside the trapdoor.
- 2) While sitting, attach two safety frames (HD20-25) one on each side by placing the lower hand above the second step of the upper shoulders and locking the two coupling hands from inside out, first on the nearest vertical upright and then accompanying the safety element with a decisive movement towards the other vertical upright, ensuring the locking pawl has clicked.

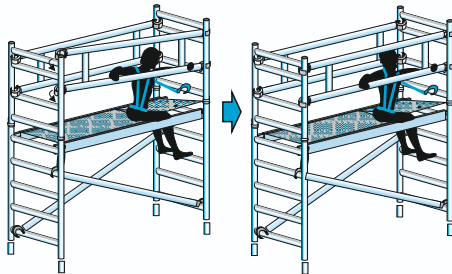

Dismantling the safety elements

- 1) On the opposite side of the trapdoor position, unhook the railing hands from the vertical tubes on both sides, letting the hands support the step (doing so, an accidental fall towards the railing would make it hook again). Then, open the trapdoor and sit on the surface with your legs inside the trapdoor.
- 2) While sitting, release one railing at a time and pass the element to the operator on the lower level.

«SAFETY POSITION AT HEIGHT ON VERTICAL ELEMENTS (S.P.A.)»

Whenever it is positioned at heights of more than m. 2 from any surface, you must use the appropriate P.P.E. to EC standard: harness with energy absorbing rope.

However, it is often necessary to use both hands to hook the upper elements, such as an upper shoulder; in these cases, it is compulsory to also use, with the harness, the positioning belt with its positioning rope.

- Wear the fall-arrest harness and the positioning belt with its ropes.
- Climb the vertical pillar to the required height, using the steps and securing yourself during ascent with the harness rope.
- Once you have reached the desired height, secure the positioning belt rope on the most comfortable step and, leaning back, push with your legs to pull the rope.



ITALIAN LEGISLATION

Legislative Decree No. 81 on 9 April 2008

Art. 111 - Employer obligations in use of equipment for work at heights

1. The employer, in cases where temporary work at a height cannot be carried out safely and under suitable ergonomic conditions from a place suitable for this purpose, selects the most suitable work equipment to ensure and maintain safe working conditions, in accordance with the following criteria:
 - a) priority for collective protection measures over individual protection measures;
 - b) the dimensions of the work equipment appropriate to the nature of the work to be carried out, the foreseeable stresses and safe movement.
2. The employer chooses the most suitable type of access system to temporary high-altitude jobs in relation to the frequency of movement, the difference in height and the duration of use. The access system used must allow evacuation in the event of imminent danger. The change from an access system to platforms, scaffolding and walkways and vice versa must not involve any additional risk of falling.
3. The employer will arrange for a ladder to be used as a workplace at height only in cases where use of other work equipment considered safer is not justified because of the low level of risk and short duration of use, or the existing characteristics of sites that cannot be modified.
4. The employer will arrange for access and positioning systems by means of ropes to which the worker is directly supported, only in circumstances following an assessment of the risks it appears that work can be carried out safely and use of other work equipment considered safer is not justified because of the short duration of use and the existing characteristics of sites which cannot be modified. The employer may include a seat with special accessories to be used, depending on the outcome of the risk assessment and in particular the duration of the work and ergonomic constraints.
5. The employer will, in relation to the type of work equipment used based on the previous paragraphs, identify measures to minimise the inherent risks to workers on such equipment, including, where necessary: installation of fall-arrest devices. These devices must be designed and constructed to prevent or stop falls from high-altitude workplaces and, as far as possible, prevent injury to workers. Collective fall-arrest devices may only be interrupted at points where ladders or steps are present.
6. The employer will take equivalent and effective safety measures if the performance of a particular job requires the temporary removal of collective protective equipment against falls. The work is carried out after these measures have been implemented. Once the work of a particular nature has been completed, either permanently or temporarily, the collective fall-arrest devices must be restored.
7. The employer performs temporary work at altitude only if the weather conditions do not endanger workers' health and safety.
8. The employer forbids drinking and serving alcoholic beverages or spirits to workers engaged in work at heights.

Art. 112 - Suitability of temporary works

2. Before any scaffolding component is reused, it must be checked to remove the components considered no longer suitable according to Annex XIX.

Art. 123 - Assembly and dismantling of temporary works

1. The assembly and dismantling of the provisional works must be carried out under the direct supervision of a supervisor of the works.

Art. 124 - Storage of materials on scaffolding

1. Storage, other than temporary storage of materials and tools necessary for work, is generally forbidden above working platforms and on scaffolding.
2. The weight of materials and persons must always be less than the structural resistance of the scaffolding; the space occupied by the materials must allow the movements and manoeuvres necessary for the work to proceed.

Art. 126- Railings

1. Scaffolding and working platforms, walkways and ramps which are placed at a height of more than 2 metres, must be fitted with sturdy railing on all sides facing the void and in good condition.

Art. 128- Underbridge

1. Scaffolding and working platform must have a safety underbridge, constructed like the platform, with a distance not exceeding 2.50 m.
2. The underbridge may be omitted for suspended platforms, cantilever platforms and when maintenance and repair work lasting no more than five days is carried out.

Art. 138 - Particular standards

3. It is forbidden to throw the scaffolding elements from above.

Art. 140 - Tower scaffolds on wheels.

- 1) Platforms on wheels must have a wide base so they can withstand, with a large safety margin, the loads and oscillations to which they may be subjected during movement or by wind and so they cannot be tilted. (*Strictly comply with the assembly instructions*)
- 2) The sliding surface of the wheels must be level; the platform load on the ground must be distributed appropriately by boards or other equivalent means
- 3) On site, the platform wheels must be securely blocked with wedges on both sides or equivalent systems.
- 4) Platforms on wheels must be anchored to the building at least every two floors; an exemption from this requirement is permitted for tower platforms on wheels in compliance with Annex XXIII (*European Standard Compliance*).
- 5) The verticality of the platforms on wheels must be checked with a level or plumb.
- 6) Platforms, excluding those used for work on electric contact lines, must not be moved when workers or loads are on them.

STAFF TRAINING

For assembly or transformation of rolling scaffold staff training, the employer is required to implement the provisions of Art. 36 and 37 of Law. 81/08, which clarifies the need to train, inform and educate workers in the use of the rolling scaffold as equipment for work at height.

Circular no. 30/2006 of the Ministry of Labour also outlines specific training for rolling scaffold assemblers.

Legislative References

- **D.L. 81** (9 April 2008): "Consolidated Safety Act"
- **Uni EN 1004** (2005): Mobile work towers (mobile scaffolds) made of prefabricated elements. Materials, components, dimensions, design loads and safety requirements".
- **D.M. 27 marzo 1998** (O.J. no. 102 on 05/05/1998): "Recognition of conformity with applicable standards safety devices and systems relating to the construction and use of tower platforms on wheels".
- **EN 1298** (February 1996): "Mobile access and working towers. Rules and guidelines for the preparation of an instruction manual".

DECLARATION OF CONFORMITY

It is declared that the ALUPONT BALCONI ES scaffold on wheels consisting of the load bearing structures ALP PSA20-25 / 1 or ALP PSA20-25 / 2 or ALP PSA20-25 / 3 and the cantilever structure ALP PSB20-25 and the cantilever structure ALP PSC, is built in compliance with Legislative Decree. No. 81 of 9 April 2008.

The same scaffold, installed and used in compliance with the procedures described in this instruction manual, or in the ALP PST20-25/ 1 - 2 - 3 configurations, complies with the European standard UNI EN 1004 relating to Ministerial Decree of 27 March 1998 (O.J. No. 102 of 05/05/1998).

FRIGERIO CARPENTERIE S.p.A.

The user's responsibility:

The manufacturer is not responsible for any damage to people or property that may result from misuse of the rolling scaffold, or from total or partial non-compliance with the rules in this booklet, or the lack of periodic checks or maintenance against any damage caused by use or weather conditions. Careful inspection of the parts of the rolling scaffold before use and compliance with the safety regulations are recommended.

PERIODIC TESTS To be filled out once a year with a Biro pen, both in case of inspection OK or otherwise, protect against dirt by applying a strip of transparent adhesive tape.

Inspection date	Part inspected	Inspection OK	Inspection NON OK	Description of fault	Name of person inspecting	Signature
Repair date	Repair type			Name of person repairing		Signature

27/09/2018	ALP MOR MG		X	Side crack	Mauro Rossi	<i>Mauro Rossi</i>
28/09/2018	clamp replacement				Matteo Milesi	<i>Matteo Milesi</i>

~~EXAMPLE~~

PERIODIC TESTS To be filled out once a year with a Biro pen, both in case of inspection OK or otherwise, protect against dirt by applying a strip of transparent adhesive tape.

Inspection date	Part inspected	Inspection OK	Inspection NOT OK	Description of fault	Name of person inspecting	Signature
Repair date	Repair type			Name of person repairing		Signature

PERIODIC TESTS To be filled out once a year with a Biro pen, both in case of inspection OK or otherwise, protect against dirt by applying a strip of transparent adhesive tape.

Inspection date	Part inspected	Inspection OK	Inspection NOT OK	Description of fault	Name of person inspecting	Signature
Repair date	Repair type			Name of person repairing		Signature



Frigerio[®]
S.p.A. CARPENTERIE

Lavora in Sicurezza!



Edition January 2024

All rights reserved. Reproduction, in full or part, of the contents of this booklet is forbidden.

Frigerio Carpenterie S.p.A.

V. Fermi 6 - 24050 Orio Al Serio (BG)

Tel. +39.035.4242311 - Fax 035.525147 -

E-mail info@frigeriospa.com - www.frigeriospa.com